

# LINEÁRIS TENGELYEK ÉS CSAPÁGYAK LINEAR SHAFTS AND BALL BUSHINGS AXE SI RULMENTI LINIARI

## ▼ TARTALOMJEGYZÉK / T.O.C. / CUPRINS

Technikai információk / Technical Informations / Informatii tehnice	140
Rendelési kód magyarázat / Order code / Codul de comanda	144
Lineáris tengelyek és csapágyak méretválasztéka / Linear shafts and ball bushings sizes / Dimensiunile axelor si ai rulmentilor liniari	145
Forgó lineáris csapágyak méretválasztéka / Rotary bushes sizes / Rulmenti liniari rotativi	170
Lineáris csúszkák méretválasztéka / Linear housing units sizes / Dimensiunile axelor si ai rulmentilor liniari	176
Talpas tengelyek és csapágyak méretválasztéka / Slide units and bushing sizes / Dimensiunile axelor si ai rulmentilor liniari cu talpa	181



Technikai információk / Technical informations / Informatii tehnice



**Hasznos élettartam**

A hasznos élettartam azt a teljes megtett távolságot jelenti, amelyet ugyanazon típusú és ugyanazon méretű termékcsoport 90%-a képes megtenni azonos üzemi feltételek mellett roncsolódás nélkül. A hasznos élettartam az alábbi egyenlet segítségével határozható meg, amelyhez a dinamikus alapterhelési érték és a lineáris rendszert érő terhelés értéke szükséges:

$$L = \left( \frac{C}{P} \right)^3 \cdot 50$$

**L:** hasznos élettartam / rating life / durata de viata utila (km)  
**C:** dinamikus alapterhelés / basic dynamic load rating / incarcarea dinamica de baza (N)  
**P:** terhelés / load / sarcina (N)

A terhelés eloszlását és annak esetleges rázkódását figyelembe kell venni egy lineáris mozgatású rendszer tervezésekor. A tényleges terhelést nem egyszerű meghatározni, továbbá a hasznos élettartam is függ például az üzemi hőmérséklettől. Ilyen feltételek mellett a statikus biztonsági tényezőt az alábbi képlettel lehet kiszámolni:

$$L = \left( \frac{f_H \cdot f_r \cdot f_c \cdot C}{f_w \cdot P} \right)^3 \cdot 50$$

Az egységidőben megadott mozgási távolság segít kiszámolni a hasznos élettartamot (órák számára lebontva). Az alábbi képlet szükséges hozzá, melyben a lökethossz és a vezetékek száma állandóként szerepel:

$$L_h = \frac{L \cdot 10^3}{2e_s \cdot n_1 \cdot 60}$$

The rating life in hours can be calculated by obtaining the travelling distance per unit time. The rating life in hours can be obtained from the following expression when the stroke length and the number of strokes are constant:

**Durata de viata utila**

Durata de viata utila reprezinta acea distanta care poate fi parcursa de 90% din piesele de acelas tip si aceleasi dimensiuni, in conditii de exploatare identice si fara defecte. Durata de viata utila poate fi determinata cu ajutorul relatiei de mai jos, cunoscand valoarea incarcarii dinamice de baza respectiv sarcina de exploatare al sistemului liniar:

La proiectarea sistemelor liniare trebuie luate in considerare distributia sarcinilor respectiv eventuala vibratie a acestora. Determinarea valorii reale a incarcarii este destul de dificil, iar durata de viata utila depinde si de factori cum ar fi temperatura de lucru. In aceste conditii coeficientul de siguranta se va determina cu ajutorul formulei:

Durata de viata utila, exprimata in ore poate fi calculata cunoscand distanta parcursa in unitatea de timp folosind expresia de mai jos, unde lungimea cursei, respectiv numarul de curse parcurse este constanta:

**Rating life**

Rating life is the total travelling distance that 90% of a group of systems of the same size can reach without causing any flaking when they operate under the same conditions. The rating life can be obtained from the following equation with the basic dynamic load rating and the load on the linear system:

Consideration and influence of vibration impact loads and distribution of load should be taken into account when designing a linear motion system, it is difficult to calculate the actual load. The rating life is also affected by the operating temperature. In these conditions, the expression (1) is arranged as follows:

The rating life in hours can be calculated by obtaining the travelling distance per unit time. The rating life in hours can be obtained from the following expression when the stroke length and the number of strokes are constant:

**Keménységi tényező (fH) (1. ábra)**

Lineáris csapágy használata esetén a lineáris tengely felületét edzeni kell. Ha a tengely nem megfelelően edzett, akkor a megengedett terhelhetőség csökken, továbbá a lineáris csapágy élettartama rövidül.

**Hardness Factor (fH) (Fig. 1.)**

The shaft must be sufficiently hardened when a linear bushing is used. If not properly hardened, permissible load is lowered and the life of the bushing will be shortened.

**Factorul de duritate (fH) (Fig. 1.)**

Axa trebuie sa aiba o duritate suficienta cand se folosesc rulmenti liniari. Daca nu are duritate suficienta, sarcina admisibila scade, si implicit si durata de viata.

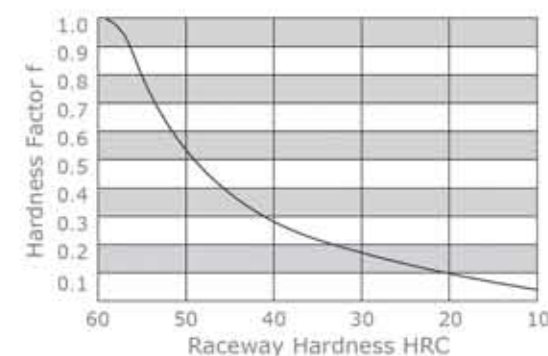

1. ábra Keménységi tényező (fH)  
Fig. 1. Hardness factor (fH)  
Fig. 1. Factorul de duritate (fH)

**Hőmérsékleti együttható (fT) (2. ábra)**

Ha a lineáris rendszer hőmérséklete meghaladja a 100°C-ot, a tengely edzettségének hatékonysága csökken, csökkentve ezzel a terhelhetőséget is a szobahőmérsékleten történő használathoz képest. Az abnormalis hőmérséklet végül a hasznos élettartam csökkenését fogja eredményezni.

**Temperature Coefficient (fT) (Fig. 2.)**

If the temperature of the linear system exceeds 100°C hardness of the linear system and the shaft lowers to decrease the permissible load compared to that of the linear system used at room temperature. As a result, the abnormal temperature rise shortens the rating life.

**Coeficientul de temperatura (fT) (Fig. 2.)**

Daca temperatura sistemului liniar trece de 100°C, duritatea sistemului liniar si al axului scade, scazand astfel si sarcina admisibila, fata de duritatea sistemului liniar care se foloseste la temperatura camerei.

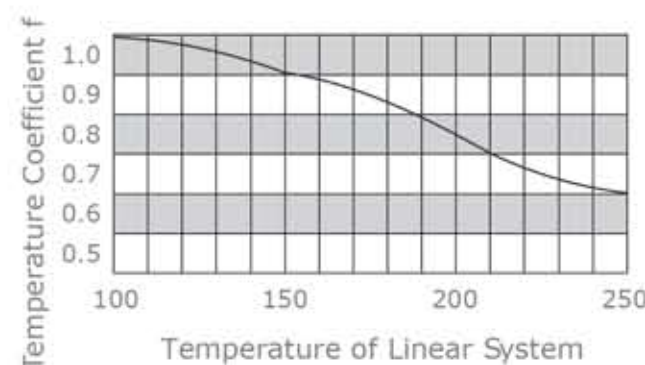

2. ábra Hőmérsékleti együttható (fT)  
Fig. 2. Temperature coefficient (fT)  
Fig. 2. Coeficientul de temperatura (fT)

**Érintkezési együttható (fc) (1. táblázat)**

Általában két, vagy több lineáris csapágy fut egy tengelyen, ezért minden egyes lineáris rendszerre nehezedő terhelés a működés pontosságától függően különbözik. Mivel a csapágyak nem egyenlő mértékben terheltek, ezért az egy tengelyen használt csapágyak száma alapján változik a rendszer megengedett terhelhetősége.

**Contact Coefficient (fc) (Table 1.)**

Generally two or more linear bushings are used on one shaft. Thus, the load on each linear system differs depending on each processing accuracy. Because the linear bushings are not loaded equally, the number of linear bushings per shaft changes the permissible load of the system.

**Coeficientul de contact (fc) (Table 1.)**

In general, doi sau mai multi rulmenti liniari se utilizeaza pe o axa. Astfel, sarcina pe fiecare sistem liniar difera in functie de precizie. Deoarece rulmentii liniari au sarcini diferite, numarul de rulmenti de pe ax schimba sarcina admisibila pe sistem.

1. TÁBLÁZAT ÉRINTKEZÉSI EGYÜTTHATÓ (FC) / TABLE 1. CONTACT COEFFICIENT (FC) / TABELUL 1. COEFICIENTUL DE CONTACT (FC)

Csapágyak száma egy tengelyen / Nr of bushing per one shaft / Numarul de rulmenti pe ax	fc
1	1
2	0,81
3	0,72
4	0,66
5	0,61

Terhelési együttható (fw) (2. táblázat)

A lineáris rendszer terhelésének kiszámításához pontosan meg kell adni a mozgatni kívánt tárgy tömegét, a mozgatási sebességből adódó tehetetlenségi erő mértékét és a nyomatékot. Ezeket az értékeket elég nehéz pontosan meghatározni, ugyanis az oda-vissza mozgásnál folyamatosan ismétlődő megállás és indulás van jelen, továbbá rázkódással és egyéb behatással is számolni kell.

Load Coefficient (fw) (Table 2.)

When calculating the load on the linear system, it is necessary to accurately obtain object weight, inertial force based on motion speed and moment load. However, it is difficult to calculate those values accurately because reciprocating motion involves the repetition of start and stop as well as vibration and impact. A more practical approach is to obtain the load coefficient by taking the actual operating conditions into account.

Coeficientul de sarcina (fw) (Table 2.)

Cand se calculeaza sarcina pe sistemul liniar, este necesar sa determinam exact masa, forta de inertie care se calculeaza din viteza si sarcina de moment. Insa, aceste valori nu pot fi valori exacte, deoarece aceste miscari implica si porniri, opriri, vibratii si impacturi. O solutie mai practica ar fi obtinerea valorii coeficientului de sarcina, luand in considerare toate conditiile de functionare.

2. TÁBLÁZAT TERHELÉSI EGYÜTTHATÓ (FW) / TABLE 2. LOAD COEFFICIENT (FW) / TABEL 2. COEFICIENTUL DE SARCINA (FW)

Működési környezet / operating conditions / Condiții de operare	fw
Alacsony sebesség (15 m/min vagy kisebb) lüktető igénybevétel nélkül Operation at low speed (15 m/min. or less) without impulsive shock from outside Functionare la viteze reduse (15 m/min. sau mai putin) fara socuri externe	1 - 1,5
Közepes sebesség (60 m/min vagy kisebb) lüktető igénybevétel nélkül Operation at intermediate speed (60 m/min. or less) without impulsive shock from outside Functionare la viteze medii (60 m/min. sau mai putin) fara socuri externe	1,5 - 2
Nagy sebesség (60 m/min felett) lüktető igénybevétellel Operation at high speed (over 60 m/min.) With impulsive shock from outside Functionare la viteze mari (60 m/min. sau mai mult) cu socuri externe	2 - 3,5

Kenés és porvédelem

Ha a lineáris rendszereket kenés nélkül használjuk, a görgős elemek kopása jelentősen megnő, az élettartam pedig csökken. A lineáris rendszerek ezért megfelelő kenést igényelnek, melyhez az ISO szabványnak megfelelő G32-G68 olaj, vagy lítium bázisú NO.2-es szappan használata javasolt. Néhány lineáris egység porvédő tömítéssel van szerelve, mely abban is segít, hogy a szíró anyagot a csapágy belsejében tartsa. Ha a termékeket mostoha, vagy korrózió környezetben használjuk, egy további védőelem használata javasolt.

Lubrication and dust prevention

Using DTE linear systems without lubrication increases the abrasion of the rolling elements, shortening the life span. The DTE linear systems therefore require appropriate lubrication. For lubrication DTE recommends turbine oil conforming to ISO Standards G32 to G68 or lithium base soap grease NO.2. Some DTE linear systems are sealed to block dust out and seal lubricant in. If used in a harsh or corrosive environment, however, apply a protective cover to the part involving linear motion.

Lubrifiere si protectie impotriva praful

Utilizarea sistemelor liniare DTE fara lubrifiere creste abraziunea la elementele de rulare, scazand durata de viata a acestora. Sistemele liniare necesita o lubrifiere adecvata, pentru cresterea duratei de viata, se recomanda utilizarea unui ulei G32-G68 in conformitate cu standardele ISO, sau al unui sapun bazic NO.2. Unele unitati liniare au o etansare care ofera protectie impotriva prafului. Acestea mai au si rolul de a tine lubrifiantul in interiorul rulmentului. Daca sistemul se va utiliza in medii corozive, se recomanda o protectie suplimentara

Beépítés

Amikor behelyezzük a lineáris csapágyat a házba ne nyomjuk meg a belső gyűrűt, mely a golyóvezetőt tartalmazza, hanem használjunk egy gyűrű alakú szerszámot amivel finoman besajtoljuk a házba a csapágyat vagy finom ütő mozdulatokkal helyezzük be azt (lásd 3. ábra). Beépítés után kerülni kell a golyósorra nehezedő lökészerű igénybevételt. Két tengely használatánál legfontosabb paraméter a tengelyek közötti párhuzamosság megtartása az egyenes lineáris mozgás érdekében. Ügyelni kell a tengelyek beállítására.

Mounting

When inserting the linear bush into the housing, do not hit the linear bush on the side ring holding the retainer but apply the cylinder circumference with a proper jig and push the linear bush into the housing by hand or lightly knock it in. (See Fig. 3.) In inserting the shaft after mounting the bush, be careful not to shock the balls. Note that if two shafts are used in parallel, the parallelism is the most important factor to assure the smooth linear movement. Take care in setting the shafts.

Montajul

Cand se monteaza rulmentul liniar in carcasa, se va evita impingerea inelului interior care conduce bilele. Se va folosi un element cilindric pentru pozitionare dupa care se monteaza cu grija (fig.3). Dupa montare se va evita socul asupra bilelor. De mentionat, ca si in cazul aplicatiilor cu doua axe, cel mai important factor pentru o functionare lina este paralelismul.

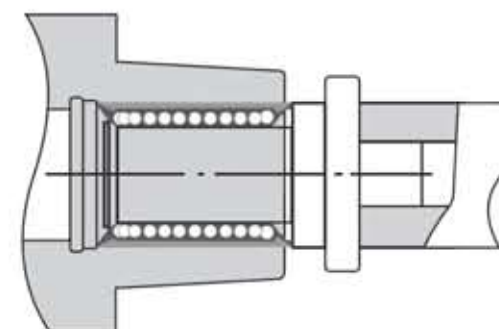

3.ábra Lineáris csapágy szerelése  
Fig. 3. Linear bearing mounting  
Fig. 3. Montajul rulmentului liniar

Rendelési kód magyarázat / Order code / Codul de comanda



LINEÁRIS CSAPÁGY KÓD FELÉPÍTÉSE / LINEAR BUSHING CODE /  
CODUL RULMENTULUI LINIAR

N	LME	A	F	20	L	UU	OP
---	-----	---	---	----	---	----	----

- standard típus / standard type / tipul standard  
 N - nikkel bevonattal / nickel plated / nichelate  
 M - rozsdamentes / anti corrosion / anticorozive  
 LM - ázsiai szabvány / asia series / seria asiatica  
 LME - európai szabvány / europe series / seria europeana  
 LMB - angol szabvány / english system series / seria britanica  
 - műanyag golyóvezető / plastic retainer / cale de rulare din material plastic  
 A - acél golyóvezető / plastic retainer / cale de rulare din otel  
 - hengeres / round / cilindric  
 F - oldal peremes / found flange / cu flansa rotunda  
 K - oldal négyzet peremes / square flange / cu flansa patrata  
 H - lapolt oldal peremes / two side cut flange / cu flansa aplatisata  
 FP - eltolt oldal peremes / pilot pattern round flange / cu flansa rotunda deplasata  
 KP - eltolt négyzet peremes / pilot pattern square flange / cu flansa patrata deplasata  
 HP - eltolt lapolt oldal peremes / pilot pattern two side cut flange / cu flansa aplatisata deplasata  
 FC - közép peremes / centered flange / cu flansa pe mijloc  
 KC - közép négyzet peremes / centered square flange / cu flansa patrata pe mijloc  
 HC - közép lapolt peremes / centered two side cut flange / cu flansa aplatisata pe mijloc  
 Tengely átmérő / shaft diameter / diametrul axului  
 - standard kivitel / standard type / tipul standard  
 S - rövid kivitel / short type / tipul scurt  
 L - hosszú kivitel / long type / tipul lung  
 - tömítés nélkül / no seal / fara etansare  
 S - egy oldalon tömített / seal one side / etansare pe o parte  
 L - két oldalon tömített / seal on both side / etansare pe ambele parti  
 - standard típus / standard type / tipul standard  
 S - precíziós típus / clearance adjustment type / tipul precis  
 L - nyitott típus / open type / tipul deschis

LINEÁRIS CSÚSZKA KÓD FELÉPÍTÉSE / SLIDE UNIT /  
CODUL PENTRU RULMENTI IN CARCASA

SC	20	L	UU
----	----	---	----

SC - zárt LM csapággal szerelt / mounting with closed LM bearing / montaj cu rulment LM inchis  
 SME - nyitott LM csapággal szerelt / mounting with open LM bearing / montaj cu rulment LM deschis  
 TBR - nyitott LM csapággal szerelt / mounting with open LM bearing / montaj cu rulment LM deschis  
 KBA - zárt LME csapággal szerelt / mounting with closed LME bearing / montaj cu rulment LME inchis  
 KBE - nyitott LME csapággal szerelt / mounting with open LME bearing / montaj cu rulment LME deschis  
 Tengely átmérő / shaft diameter / diametrul axului  
 - standard kivitel / standard type / varianta standard  
 S - rövid kivitel / short type / varianta scurta  
 L - hosszú kivitel / long type / varianta lunga  
 - tömítés nélkül / no seal / fara etansare  
 S - egy oldalon tömített / seal one side / etansare pe o parte  
 L - két oldalon tömített / seal on both side / etansare pe ambele parti

Lineáris tengelyek és csapágyak méretválasztéka / Linear shafts and ball bushings sizes / Dimensiunile axelor si ai rulmentilor liniari



SF TÖMÖR TENGELY / SF SHAFT / AXA PLINA SF

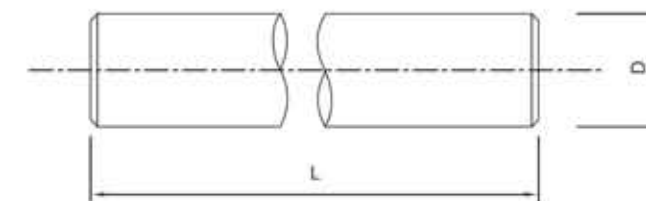

Típus Type Tipul	D h6	L Max. hossz Max. length Lungimea maxima	Edzett réteg vastagság Surface hardness depth Adancimea duritatii de suprafata	Körköröség Roundness Concentricitatea	Párhuzamosság Parallelism Paralelism	Tömeg Weight Masa	
	(mm)	(mm)	(µm)	(µm)	(µm)	(kg/m)	
SF 4	4	2000	0,5-0,8	3	4	0,1	
SF 6	6		0,5-0,8	4	6	0,23	
SF 8	8		0,6-0,9	4	6	0,4	
SF 10	10		0,7-1	4	6	0,62	
SF 12	12		0,8-1,2	5	8	0,89	
SF 14	14		0,8-1,2	5	8	1,21	
SF 16	16	4000	0,9-1,3	5	8	1,58	
SF 18	18		1,1-1,5	5	8	2	
SF 20	20		1,2-1,5	6	8	2,47	
SF 22	22		1,2-1,5	6	8	2,98	
SF 25	25		1,5-1,7	6	9	3,85	
SF 28	28		1,5-1,7	6	9	4,83	
SF 30	30		6000	1,5-1,9	6	9	5,55
SF 35	35			1,8-1,9	7	11	7,55
SF 40	40			1,9-2	7	11	9,87
SF 50	50			1,6-2	7	11	15,4
SF 60	60	2,2-2,6		8	13	18,64	
SF 70	70	2,2-2,6		8	13	22,2	
SF 80	80	2,2-2,6		8	13	30,2	
SF 90	90	2,2-3,2		8	13	49,92	
SF 100	100	2,2-3,2		8	13	61,62	

A tengely anyag: C45 vagy CK55  
Shaft material: C45 or CK55  
Materialul axului: C45 sau CK55

LINEÁRIS TENGELYEK ÉS CSAPÁGYAK  
LINEAR SHAFTS AND BALL BUSHINGS  
AXE SI RULMENTI LINIARI

WH CSÖTENGEY / WH HOLLOW SHAFT / AXE TEAVA TIP WH

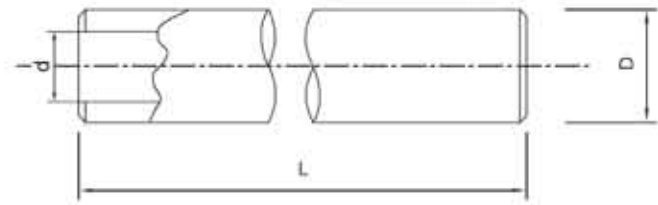

Típus Type Tipul	D h6 (mm)	d (±10%) (mm)	L Max. hossz Max. length Lungimea maxima (mm)	Edzett réteg vastagság Surface hardness depth Duritatea la suprafata (μm)	Körköröség Roundness Concentricitate (μm)	Párhuzamosság Parallelism Paralelism (μm)	Tömeg Weight Masa (kg/m)
WH 16	16	7	6000	1,1-1,5	8	11	1,28
WH 20	20	14		1,2-1,5	9	13	1,25
WH 25	25	15,6		1,5-1,7	9	13	2,35
WH 30	30	18,3		1,5-1,9	9	13	3,5
WH 40	40	28		1,9-2	11	16	4,99
WH 50	50	29,7		2,2-2,6	11	16	9,91
WH 60	60	36		2,2-2,6	13	13	14,2
WH 80	80	57		2,2-2,6	13	13	19,43

A tengely anyag: CK60  
Shaft material: CK60  
Materialul axului: CK60

LINEÁRIS TENGELYEK ÉS CSAPÁGYAK  
LINEAR SHAFTS AND BALL BUSHINGS  
AXE SI RULMENTI LINIARI

WRA ROZSDAMENTES TENGEY / WRA STAINLESS STEEL SHAFT /  
AXE DIN OTEL INOXIDABIL WRA

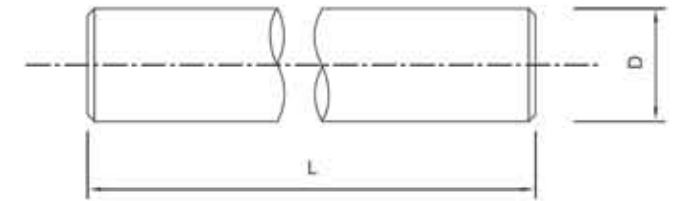

Típus Type Tipul	D h6 (mm)	d (±10%) (mm)	L Max. hossz Max. length Lungimea maxima (mm)	Edzett réteg vastagság Surface hardness depth Duritatea la suprafata (μm)	Körköröség Roundness Concentricitate (μm)	Párhuzamosság Parallelism Paralelism (μm)	
WRA 5	5	3200	0,5-0,8	4	5	0,16	
WRA 6	6		0,5-0,8	4	5	1,23	
WRA 8	8		0,6-0,9	4	6	0,4	
WRA 10	10		0,7-1	4	6	0,62	
WRA 12	12		0,8-1,2	5	8	0,89	
WRA 14	14		0,9-1,3	5	8	1,21	
WRA 15	15		1-1,4	5	8	1,39	
WRA 16	16		6000	1,1-1,5	5	8	1,58
WRA 20	20			1,2-1,5	6	9	2,47
WRA 25	25			1,5-1,7	6	9	3,85
WRA 30	30			1,5-1,9	6	9	5,55
WRA 40	40			1,9-2	7	11	9,87
WRA 50	50			2,2-2,6	7	11	15,4
WRA 60	60			2,2-2,6	8	13	22,2

A tengely anyag: X90CrMoV18 / AISI440B  
Shaft material: X90CrMoV18 / AISI440B  
Materialul axului: X90CrMoV18 / AISI440B

LINEÁRIS TENGELYEK ÉS CSAPÁGYAK  
LINEAR SHAFTS AND BALL BUSHINGS  
AXE SI RULMENTI LINIARI

WRB ROZSDAMENTES TENGELY / WRB STAINLESS STEEL SHAFT /  
AXE DIN OTEL INOXIDABIL WRB

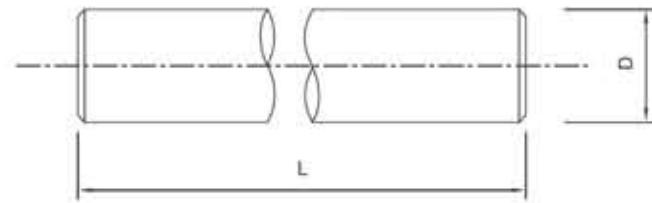

Típus Type Tipul	D h6 (mm)	d (±10%) (mm)	L Max. hossz Max. length Lungimea maxima (mm)	Edzett réteg vastagság Surface hardness depth Duritatea la suprafata (µm)	Körköröség Roundness Concentricitate (µm)	Párhuzamosság Parallelism Paralelism (µm)
WRB 8	8	6000	0,6-0,9	4	6	0,4
WRB 10	10		0,7-1	4	6	0,62
WRB 12	12		0,8-1,2	5	8	0,89
WRB 14	14		0,9-1,3	5	8	1,21
WRB 16	16		1,1-1,5	5	8	1,58
WRB 20	20		1,2-1,5	6	9	2,47
WRB 25	25		1,5-1,7	6	9	3,85
WRB 30	30		1,5-1,9	6	9	5,55
WRB 40	40		1,9-2	7	11	9,87
WRB 50	50		2,2-2,6	7	11	15,4

A tengely anyag: X46Cr13 / AISI430C  
Shaft material: X46Cr13 / AISI430C  
Materialul axului: X46Cr13 / AISI430C

LINEÁRIS TENGELYEK ÉS CSAPÁGYAK  
LINEAR SHAFTS AND BALL BUSHINGS  
AXE SI RULMENTI LINIARI

SK RÚDTARTÓ / SK SLIDE UNIT / SPRIJIN TIP SK

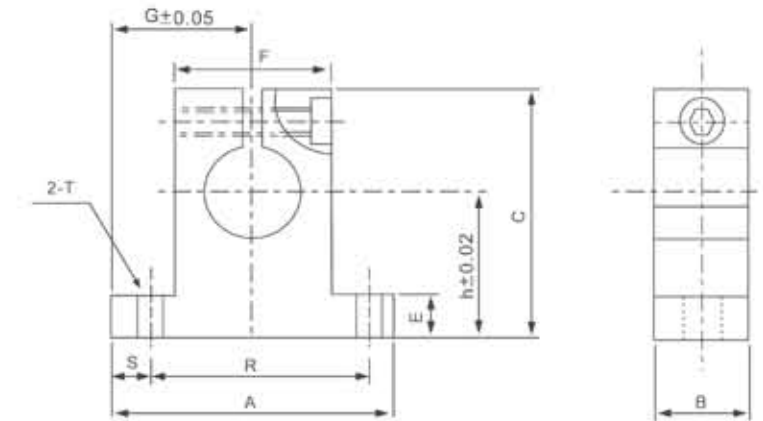

Típus Type Tipul	Tengely Ø Shaft Ø ØAx	h	G	A	B	C	E	F	R	S	T	Befogó csavar Clamping bolt Surub de fixare	Rögzítő csavar Mounting bolt Surub de montare	Tömeg Weight Masa (g)
SK-8	8	20	21	42	14	32,8	6	18	32	5	5,5	M4	M5	24
SK-10	10	20	21	42	14	32,8	6	18	32	5	5,5	M4	M5	24
SK-12	12	23	21	42	14	37,5	6	20	32	5	5,5	M4	M5	30
SK-13	13	23	21	42	14	37,5	6	20	32	5	5,5	M4	M5	30
SK-16	16	27	24	48	16	44	8	25	38	5	5,5	M4	M5	40
SK-20	20	31	30	60	20	51	10	30	45	7,5	6,6	M5	M6	70
SK-25	25	35	35	70	24	60	12	38	56	7	6,6	M6	M6	130
SK-30	30	42	42	84	28	70	12	44	64	10	9	M6	M8	180
SK-35	35	50	49	98	32	82	15	50	74	12	11	M8	M10	270
SK-40	40	60	57	114	36	96	15	60	90	12	11	M8	M10	420
SK-50	50	70	63	126	40	120	18	74	100	13	14	M12	M12	750

LINEÁRIS TENGELEK ÉS CSAPÁGYAK  
LINEAR SHAFTS AND BALL BUSHINGS  
AXE SI RULMENTI LINIARI

SHF RÚDTARTÓ / SHF SLIDE UNIT / SPRIJIN TIP SHF

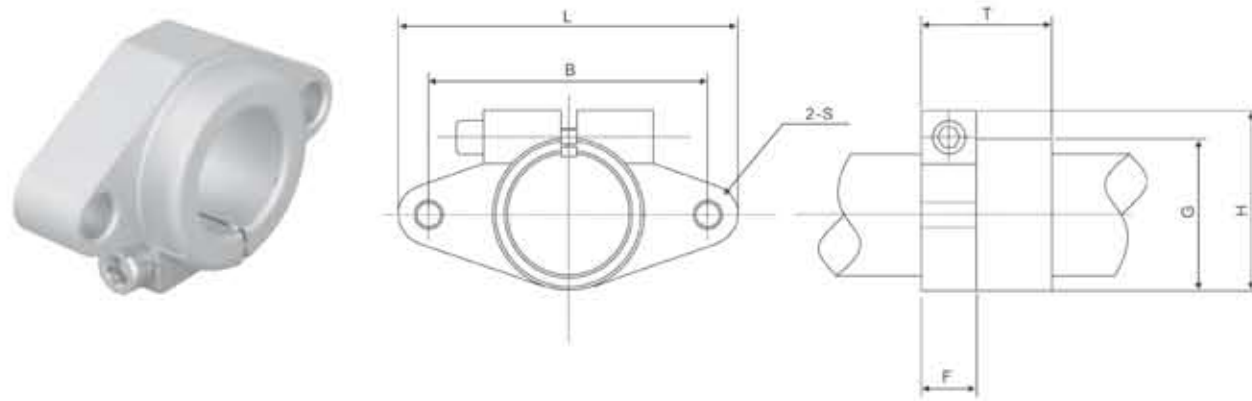

Típus Type Tip	Tengely Ø Shaft Ø ØAxa	L	T	F	B	G	H	S	Befogó csavar Clamping bolt Suruburi de fixare	Rögzítő csavar Mounting bolt Suruburi de montare	Tömeg Weight Masa
SHF-10	10	43	10	5	32	20	24	6	M5	M4	13
SHF-12	12	47	13	7	36	25	28	6	M5	M4	20
SHF-13	13	47	13	7	36	25	28	6	M5	M4	20
SHF-16	16	50	16	8	40	28	31	6	M5	M4	27
SHF-20	20	60	20	8	48	34	37	7	M6	M5	40
SHF-25	25	70	25	10	56	40	42	7	M6	M5	60
SHF-30	30	80	30	12	64	46	50	9	M8	M6	110
SHF-35	35	92	35	14	72	50	58	12	M10	M8	380
SHF-40	40	##	40	16	80	56	67	12	M10	M10	510
SHF-50	50	##	50	19	96	70	83	14	M12	M12	890

LINEÁRIS TENGELEK ÉS CSAPÁGYAK  
LINEAR SHAFTS AND BALL BUSHINGS  
AXE SI RULMENTI LINIARI

SFWR RÚDTARTÓ / SFWR SLIDE UNIT / SPRIJIN TIP SFWR

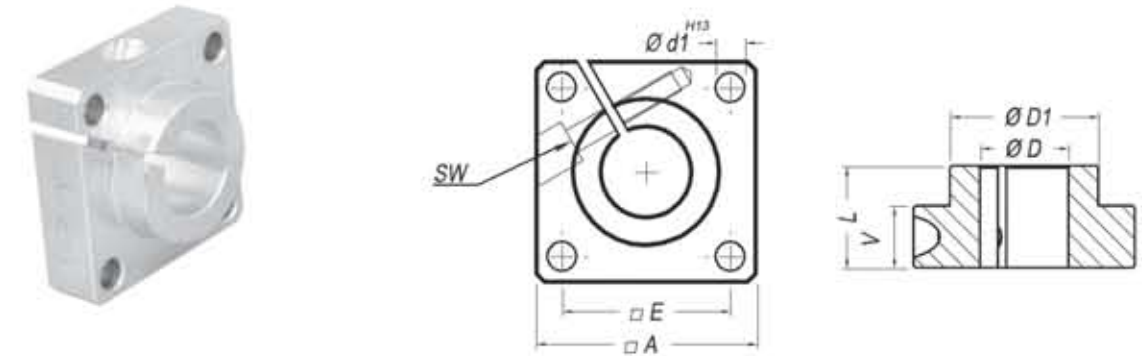

Típus Type Tipul	D	A	L	D1	E	d1	V	SW	Tömeg Weight Masa
SFWR-12	12	40	20	23,5	30	5,5	12	M3	50
SFWR-16	16	50	20	27,5	35	5,5	12	M3	80
SFWR-20	20	50	23	33,5	38	6,6	14	M4	100
SFWR-25	25	60	25	42	42	6,6	16	M5	150
SFWR-30	30	70	30	49,5	54	9	19	M6	240
SFWR-40	40	100	40	65	68	11	26	M8	660
SFWR-50	50	100	50	75	75	11	36	M8	820

FGWN RÚDTARTÓ / FGWN SLIDE UNIT / SPRIJIN TIP FGWN

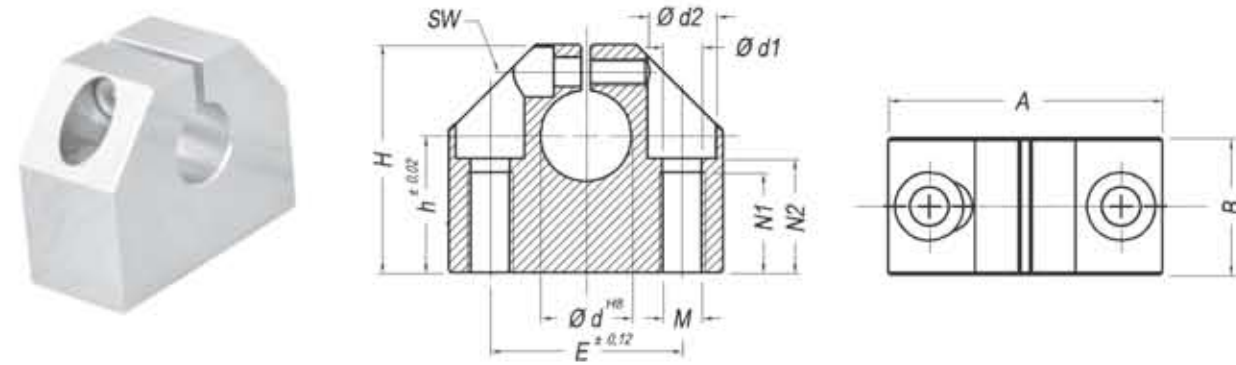

Típus Type Tipul	d	A	B	H	h	E	d1	d2	M	N1	N2	SW	Tömeg Weight Masa
													(g)
(mm)													
FGWN-8	8	32	18	28	15	22	3,3	6	M4	9	13	M3	30
FGWN-12	12	43	20	35	20	30	5,2	10	M6	13	16,5	M3	60
FGWN-16	16	53	24	42	25	38	6,8	11	M8	18	21	M4	110
FGWN-20	20	60	30	50	30	42	8,6	15	M10	22	25	M5	170
FGWN-25	25	78	38	61	35	56	10,3	18	M12	26	30	M6	360
FGWN-30	30	87	40	70	40	64	10,3	18	M12	26	34	M6	460
FGWN-40	40	108	48	90	50	82	14,25	20	M16	34	44	M8	860
FGWN-50	50	132	58	105	60	100	17,5	26	M20	43	49	M10	1450

KTA RÚDTARTÓ / KTA SLIDE UNIT / SPRIJIN TIP KTA

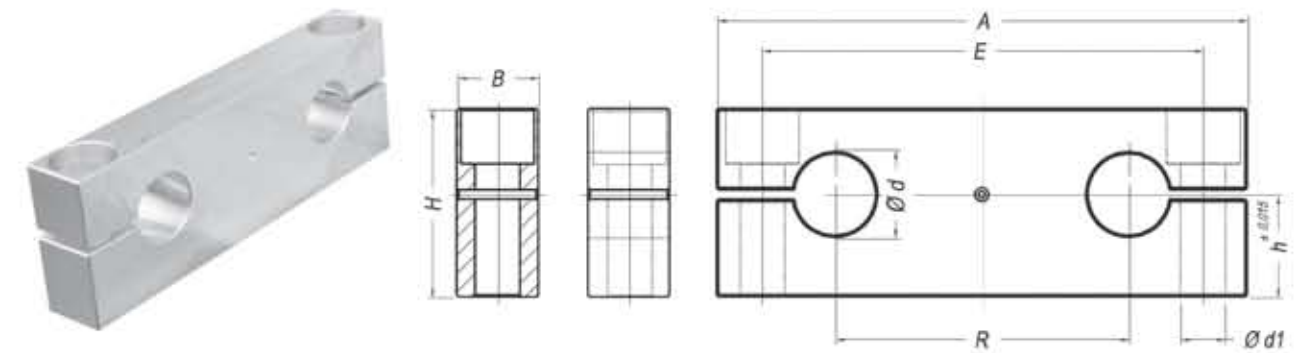

Típus Type Tipul	d	A	B	H	h	E	R	Tömeg Weight Masa
								(g)
(mm)								
KTA-8	8	65	12	23	12,5	52	32	40
KTA-12	12	85	14	32	18	70	42	90
KTA-16	16	100	18	36	20	82	54	140
KTA-20	20	130	20	46	25	108	72	260
KTA-25	25	160	25	56	30	132	88	470
KTA-30	30	180	25	64	35	150	96	630
KTA-40	40	230	30	80	44	190	122	1100
KTA-50	50	280	30	96	52	240	152	1650



LINEÁRIS TENGELEK ÉS CSAPÁGYAK  
LINEAR SHAFTS AND BALL BUSHINGS  
AXE SI RULMENTI LINIARI

► HKR RÖGZÍTŐ ELEM / HKR CLAMPING ELEMENT / ELEMENT DE FIXARE HKR

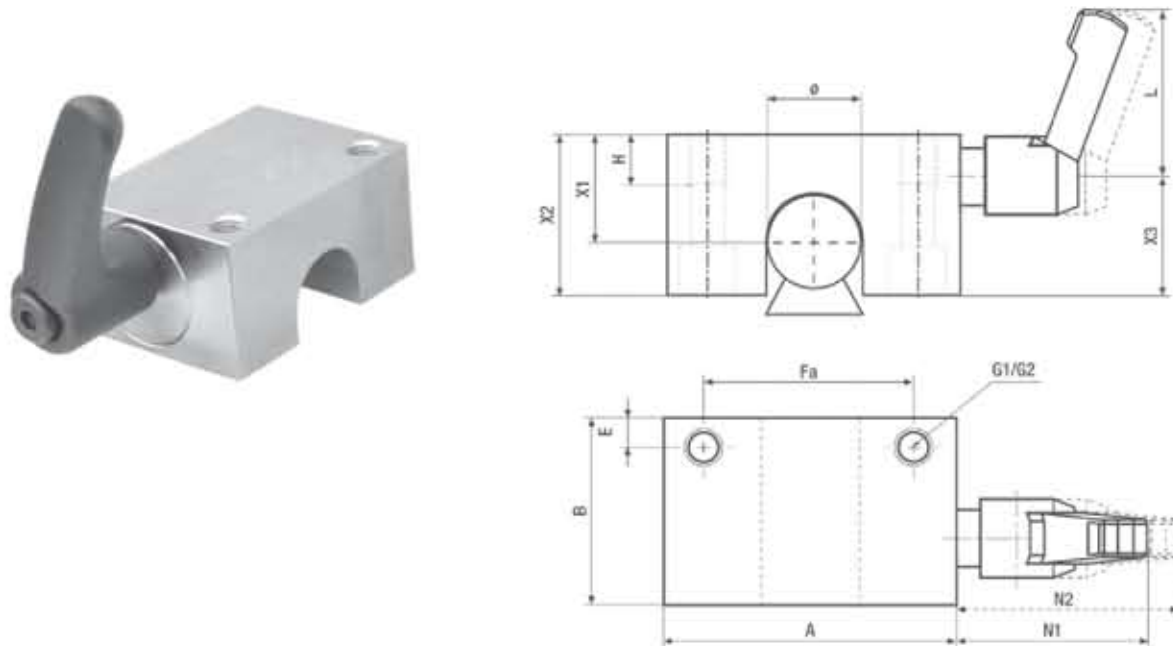

Típus Type Tipul	F.M (N) / C.S (Nm)	d	A	Fa	N2	N1	B	E	X1	X2	X3	H	L	G1	G2
HKR-1200A	1200 / 5	12	43	32	30,5	33,5	32	4,5	18	24	16	10	44	M5	M4
HKR-1600A	1200 / 5	16	53	40	30,5	33,5	38	5,5	22	29	19	12	44	M6	M5
HKR-2000A	1200 / 7	20	60	45	38,5	41,5	44	6,5	25	32	21,5	14	63	M8	M6
HKR-2500A	1200 / 7	25	78	60	38,5	41,5	52	9	30	38	25	16	63	M10	M8
HKR-3000A	2000 / 15	30	87	68	46,5	50,5	58	10	35	43	28,5	16	78	M10	M8
HKR-4000A	2000 / 22	40	108	86	56,5	61,5	68	11	45	53	34,5	20	95	M12	M10
HKR-5000A	2000 / 36	50	132	108	56,5	61,5	76	12	50	58	39,5	22	95	M16	M14

F.M – Rögzítő erő / fixing power / forta de fixare

C.S – Meghúzó nyomaték / fastening torque / momentul de fixare

LINEÁRIS TENGELEK ÉS CSAPÁGYAK  
LINEAR SHAFTS AND BALL BUSHINGS  
AXE SI RULMENTI LINIARI

► KH SOROZAT / KH SERIES / SERIA KH

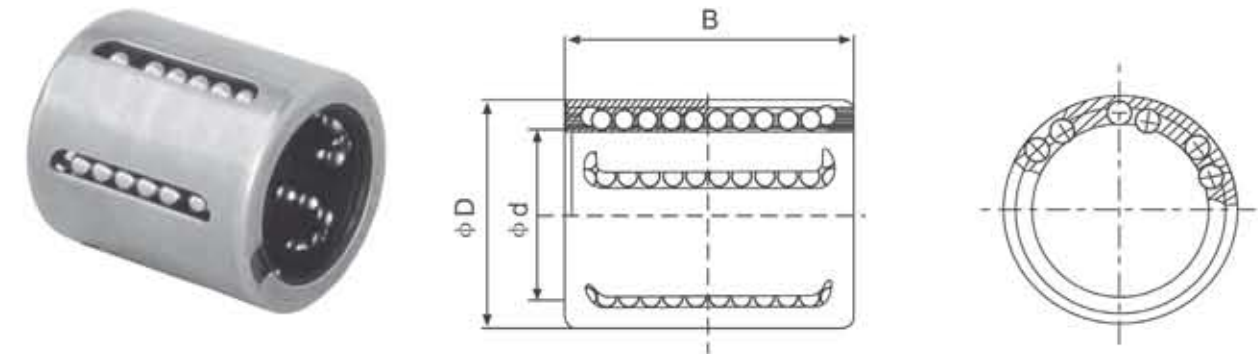

Típus Type Tipul	d (mm)	D (mm)	B (mm)	Terhelés / Load / Sarcina		Tömeg Weight Masa (g)
				C (N)	C0 (N)	
KH-0622	6	12	22	400	239	7
KH-0824	8	15	24	435	280	12
KH-1026	10	17	26	500	370	14,5
KH-1228	12	19	28	620	510	18,5
KH-1428	14	21	28	620	520	20,5
KH-1630	16	24	30	800	620	27,5
KH-2030	20	28	30	950	790	32,5
KH-2540	25	35	40	1990	1670	66
KH-3050	30	40	50	2800	2700	95
KH-4060	40	52	60	4400	4450	182
KH-5070	50	62	70	5500	6300	252

► LME SOROZAT (EURÓPAI SZABVÁNY) / LME SERIES (EUROPE SERIES) /  
SERIA LME (SERIA EUROPEANA)

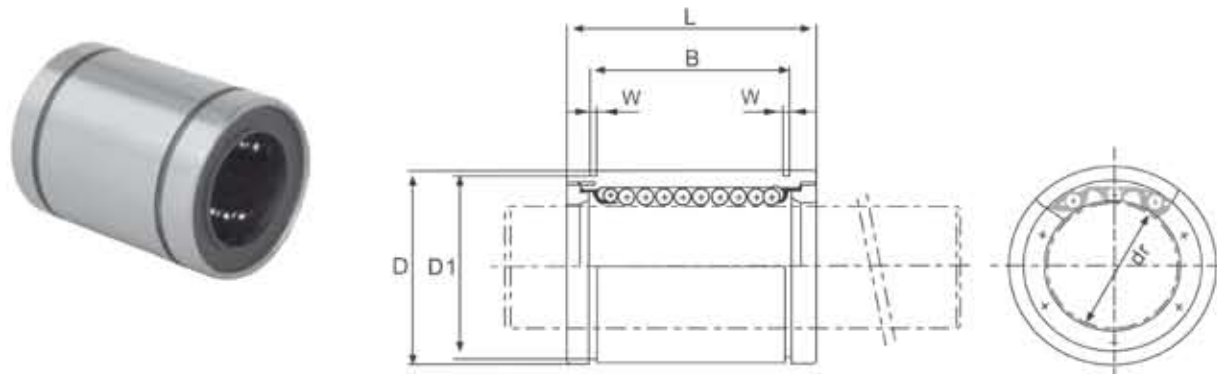

Típus Type Tipul	Golyó sorok Ball circuit Circuite de bile	dr		D		L		B		D1		W		Excentri- kusság Eccentricity Excentricitate (max.) (μm)	Radiális eltérés Radial clearance Abateri radiale (max.) (μm)	Terhelés Load Sarcina		Tömeg Weight Masa (g)
		(mm)	(μm)	(mm)	(μm)	(mm)	(μm)	(mm)	(μm)	(mm)	(μm)	(mm)	(μm)			C	C0	
		(mm)	(μm)	(mm)	(μm)	(mm)	(μm)	(mm)	(μm)	(mm)	(μm)	(mm)	(μm)			(N)	(N)	
LME 5UU	4	5		12	0	22		14,5		11,5	1,1			12	-3	206	265	11
LME 8UU	4	8	+8 0	16	-8	25		16,5		15,2	1,1			12	-3	265	402	22
LME 12UU	4	12		22	0	32	0 -200	22,9	0 -300	21	1,3			12	-4	510	784	45
LME 16UU	5	16	+9	26	-9	36		24,9		24,9	1,3			12	-4	578	892	60
LME 20UU	5	20	+1	32		45		31,5		30,3	1,6			15	-6	862	1370	102
LME 25UU	6	25	+11	40	0 -11	58		44,1		37,5	1,85			15	-6	980	1570	235
LME 30UU	6	30	-1	47		68	0	52,1		44,5	1,85			15	-8	1570	2740	360
LME 40UU	6	40		62	0	80	-300	60,6	0	59	2,15			17	-8	2160	4020	770
LME 50UU	6	50	+13 -2	75	-13	100		77,6	-400	72	2,65			17	-13	3820	7940	1250
LME 60UU	6	60		90	0 /-15	125	0 /-400	86,5		86,5	3,15			20	-13	4700	9800	2220

► LME\_L SOROZAT (EURÓPAI SZABVÁNY) / LME\_L SERIES (EUROPE SERIES) /  
SERIA LME\_L (SERIA EUROPEANA)

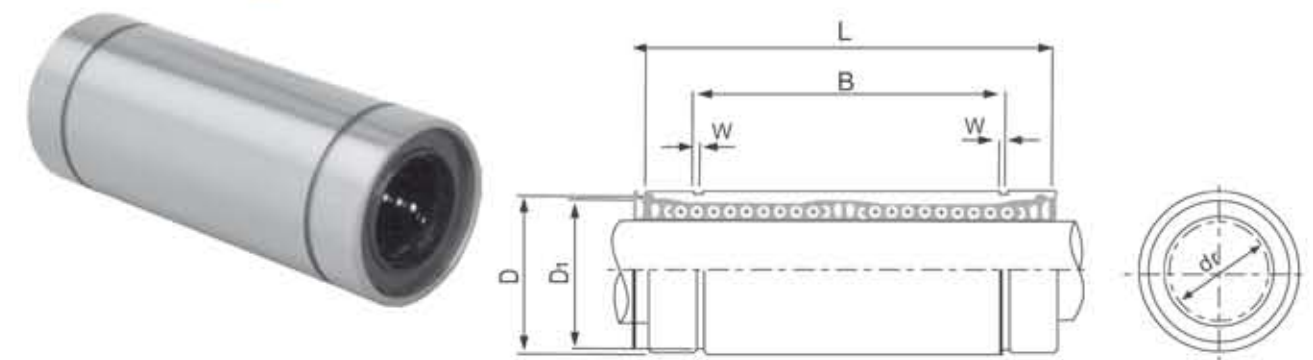

Típus Type Tipul	Golyó sorok Ball circuit Circuite de bile	dr		D		L		B		D1		W		Excentri- kusság Eccentricity Excentricitate (max.) (μm)	Radiális eltérés Radial clearance Abateri radiale (max.) (μm)		Tömeg Weight Masa (g)	
		(mm)	(μm)	(mm)	(μm)	(mm)	(μm)	(mm)	(μm)	(mm)	(μm)	(mm)	(μm)		C	C0		
		(mm)	(μm)	(mm)	(μm)	(mm)	(μm)	(mm)	(μm)	(mm)	(μm)	(mm)	(μm)		(N)	(N)		
LME8LUU	4	8	+9	16	0-9	46		33		15,2	1,1			15	-3	421	804	40
LME12LUU	4	12	+1	22	0	61	0	45,8	0	21	1,3			15	-3	813	1570	80
LME16LUU	5	16	+11	26	-11	68	-300	49,8	-400	24,9	1,3			15	-3	921	1780	115
LME20LUU	5	20	-1	32		80		61		30,3	1,6			15	-3	1370	2740	180
LME25LUU	6	25	+13	40	0 -13	112		82		37,5	1,85			17	-3	1570	3140	430
LME30LUU	6	30	-2	47		123		104,2		44,5	1,85			17	-3	2500	5490	615
LME40LUU	6	40		62	0	151	0 -400	121,2	0 -500	59	2,15			20	-3	3430	8040	1400
LME50LUU	6	50	+16 -4	75	-15	192		155,2		72	2,65			20	-3	6080	15900	2320
LME60LUU	6	60		90	0/-20	209		170		86,5	3,15			25	-3	7550	20000	3900

► **LMEH SOROZAT (EURÓPAI SZABVÁNY) / LMEH SERIES (EUROPE SERIES) /  
SERIA LMEH**

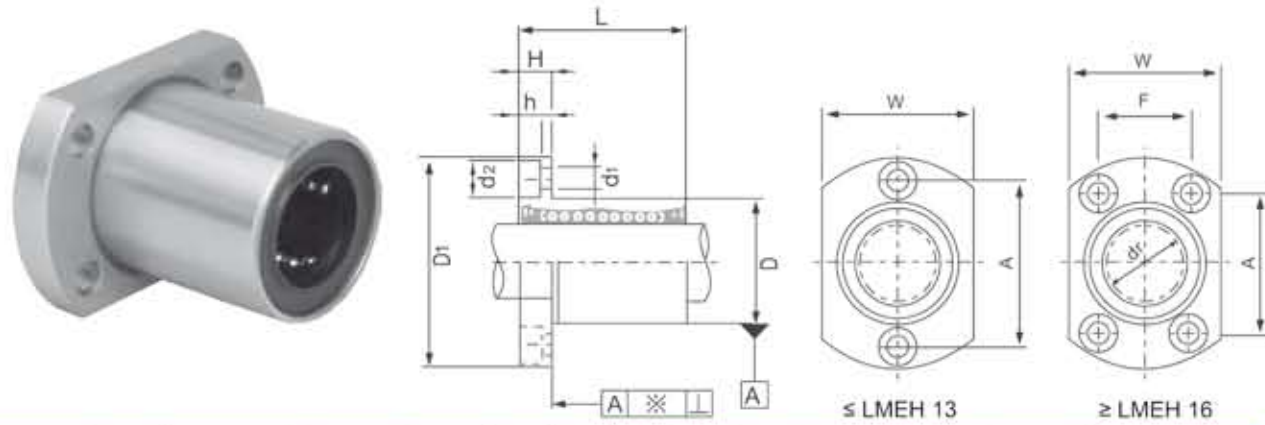

Típus Type Tipul	Golyó sorok Ball circuit Circuitul de bile	dr		D		L (±0,3)	D1	W	A	F	H	d1xd2xh	Excent- rikusság Eccentri- city Excentri- citate (max.)	Radiális eltérés Radial clearance Abatere radiala (max.)	Terhelés Load Sarcina		Tömeg Weight Masa
		(mm)	(µm)	(mm)	(µm)										C	C0	
LMEH12UU	4	12	+8/0	22	0	32	42	32	32	-	6	4,5x7,5x4,1	12	-4	510	784	80
LMEH16UU	5	16	+9	26	-13	36	46	34	31	22	6	4,5x7,5x4,1			578	892	103
LMEH20UU	5	20	+1	32		45	54	39	36	24	8	5,5x9x5,1			862	1370	182
LMEH25UU	6	25	+11	40	0	58	62	42	40	32	8	5,5x9x5,1	15	-6	980	1570	335
LMEH30UU	6	30	-1	47	-16	68	76	54	49	35	10	6,6x11x6,1		-8	1570	2740	560

► **LMEF SOROZAT (EURÓPAI SZABVÁNY) / LMEF SERIES  
(EUROPE SERIES) / SERIA LMEF (SERIA EUROPEANA)**

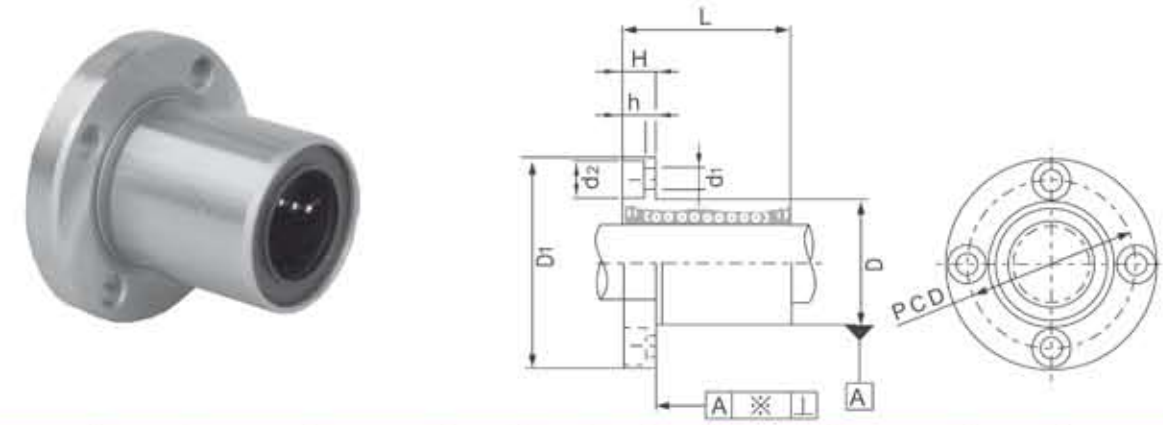

Típus Type Tipul	Golyó sorok Ball circuit Circuitul de bile	dr		D		L (±0,3)	D1	PCD	H	d1xd2xh	Excent- rikusság Eccentri- city Excentri- citate (max.)	Radiális eltérés Radial clearance Abatere radiala (max.)	Terhelés Load Sarcina		Tömeg Weight Masa
		(mm)	(µm)	(mm)	(µm)								C	C0	
LMEF8UU	4	8	+8	16	0/-11	25	32	24	5	3,5x6x3,1		-3	265	402	41
LMEF12UU	4	12	0	22	0	32	42	32	6	4,5x7,5x4,1	12	-4	510	784	80
LMEF16UU	5	16	+9	26	-13	36	46	36	6	4,5x7,5x4,1			578	892	103
LMEF20UU	5	20	+1	32		45	54	43	8	5,5x9x5,1			862	1370	182
LMEF25UU	6	25	+11	40	0	58	62	51	8	5,5x9x5,1	15	-6	980	1570	335
LMEF30UU	6	30	-1	47	-16	68	76	62	10	6,6x11x6,1		-8	1570	2740	560
LMEF40UU	6	40		62	0	80	98	80	13	9x14x8,1	20		2160	4020	1175
LMEF50UU	6	50	+13	75	-19	100	112	94	13	9x14x8,1		-13	3820	7940	1745
LMEF60UU	6	60	-2	90	0/-22	125	134	112	18	11x17x11,1	25		4700	9800	3220

LINEÁRIS TENGELEK ÉS CSAPÁGYAK  
LINEAR SHAFTS AND BALL BUSHINGS  
AXE SI RULMENTI LINIARI

► LMEF\_L SOROZAT (EURÓPAI SZABVÁNY) / LMEF\_L SERIES  
(EUROPE SERIES) / SERIA LMEF\_L (SERIA EUROPEANA)

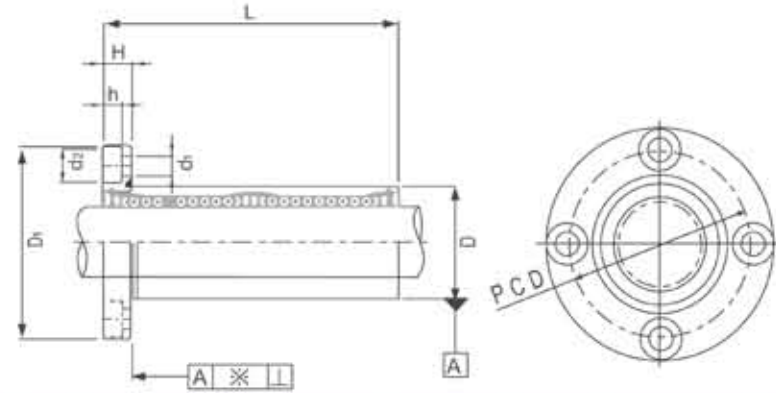

Típus Type Tipul	Golyó sorok Ball circuit Circuitul de bile	dr		D		L (±0,3)	D1	PCD	H	d1xd2xh	Excent- rikusság Eccentricity Excentricitate (max.)	Radiális eltérés Radial clearance Abatere radiala (max.)	Terhelés Load Sarcina		Tömeg Weight Masa
		(mm)	(µm)	(mm)	(µm)								C	C0	
LMEF8LUU	4	8	+9	16	0/-13	46	32	24	5	3,5x6x3,1	15	-3	421	804	59
LMEF12LUU	4	12	+1	22	0	61	42	32	6	4,5x7,5x4,1		-4	813	1570	110
LMEF16LUU	5	16	+11	26	-16	68	46	36	6	4,5x7,5x4,1	17	-6	921	1780	160
LMEF20LUU	5	20	+1	32	0	80	54	43	8	5,5x9x5,1		-6	1370	2740	260
LMEF25LUU	6	25	+13	40	-19	112	62	51	8	5,5x9x5,1	20	-8	1570	3140	540
LMEF30LUU	6	30	-2	47	0	123	76	62	10	6,6x11x6,1		-8	2500	5490	815
LMEF40LUU	6	40	+16 -4	62	0	151	98	80	13	9x14x8,1	25	-13	3430	8040	1805
LMEF50LUU	6	50		-22	192	112	94	13	9x14x8,1	-13		6080	15900	2820	
LMEF60LUU	6	60		90	0/-25	209	134	112	18	11x17x11,1			7550	20000	4920

LINEÁRIS TENGELEK ÉS CSAPÁGYAK  
LINEAR SHAFTS AND BALL BUSHINGS  
AXE SI RULMENTI LINIARI

► LMEK SOROZAT (EURÓPAI SZABVÁNY) / LMEK SERIES  
(EUROPE SERIES) / SERIA LMEK (SERIA EUROPEANA)

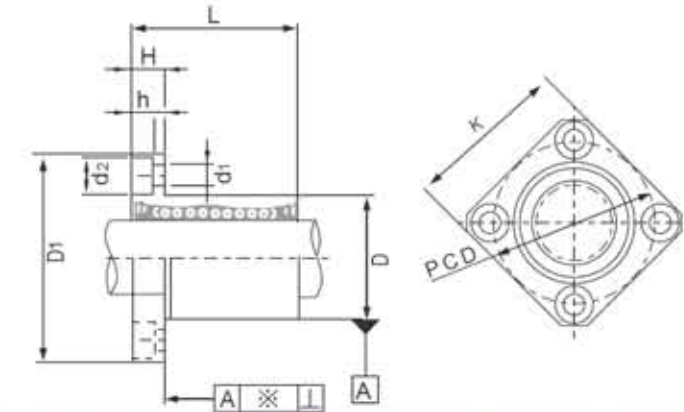

Típus Type Tipul	Golyó sorok Ball circuit Circuitul de bile	dr		D		L (±0,3)	D1	PCD	K	H	d1xd2xh	Excent- rikusság Eccentricity Excentricitate (max.)	Radiális eltérés Radial clearance Abatere radiala (max.)	Terhelés Load Sarcina		Tömeg Weight Masa
		(mm)	(µm)	(mm)	(µm)									C	C0	
LMEK8UU	4	8	+8	16	0/-11	25	32	24	25	5	3,5x6x3,1	12	-3	265	402	41
LMEK12UU	4	12	0	22	0	32	42	32	32	6	4,5x7,5x4,1		-4	510	784	80
LMEK16UU	5	16	+9	26	-13	36	46	36	35	6	4,5x7,5x4,1	15	-6	578	892	103
LMEK20UU	5	20	+1	32	0	45	54	43	42	8	5,5x9x5,1		-6	862	1370	182
LMEK25UU	6	25	+11	40	-16	58	62	51	50	8	5,5x9x5,1	20	-8	980	1570	335
LMEK30UU	6	30	-1	47	0	68	76	62	60	10	6,6x11x6,1		-8	1570	2740	560
LMEK40UU	6	40	+13 -2	62	0	80	98	80	75	13	9x14x8,1	25	-13	2160	4020	1175
LMEK50UU	6	50		-19	75	-19	100	112	94	88	13		9x14x8,1	-13	3820	7940
LMEK60UU	6	60		90	0/-22	125	134	112	106	18	11x17x11,1			4700	9800	3220

► **LMEK\_L SOROZAT (EURÓPAI SZABVÁNY) / LMEK\_L SERIES (EUROPE SERIES) / SERIA LMEK\_L (SERIA EUROPEANA)**

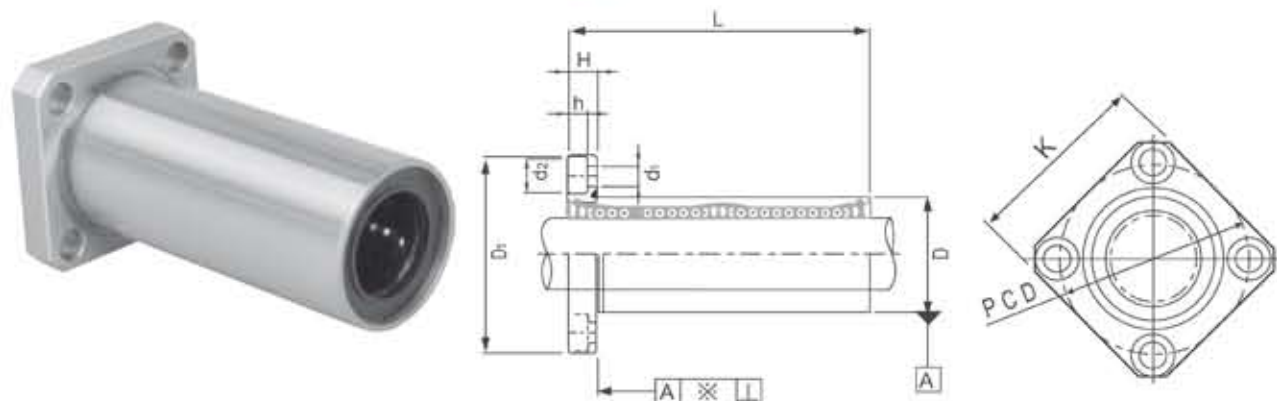

Típus Type Tipul	Golyó sorok Ball circuit Circuitul de bile	dr		D		L (±0,3)	D1	PCD	K	H	d1xd2xh	Excent- rikusság Eccentrici- tate (max.) (µm)	Radiális eltérés Radial clearance Abatere radiala (max.) (µm)	Terhelés Load Sarcina (N)		Tömeg Weight Masa (g)
		(mm)	(µm)	(mm)	(µm)									C	C0	
LMEK8LUU	4	8	+9	16	0/-13	46	32	24	5	25	3,5x6x3,1	15	-3	421	804	59
LMEK12LUU	4	12	+1	22	0	61	42	32	6	32	4,5x7,5x4,1	15	-4	813	1570	110
LMEK16LUU	5	16	+11	26	-16	68	46	36	6	35	4,5x7,5x4,1	15	-4	921	1780	160
LMEK20LUU	5	20	+1	32	0	80	54	43	8	42	5,5x9x5,1	17	-6	1370	2740	260
LMEK25LUU	6	25	+13	40	0	112	62	51	8	50	5,5x9x5,1	17	-6	1570	3140	540
LMEK30LUU	6	30	-2	47	0	123	76	62	10	60	6,6x11x6,1	20	-8	2500	5490	815
LMEK40LUU	6	40	+16	62	0	151	98	80	13	75	9x14x8,1	20	-8	3430	8040	1805
LMEK50LUU	6	50	-4	75	-22	192	112	94	13	88	9x14x8,1	25	-13	6080	15900	2820
LMEK60LUU	6	60		90	0/-25	209	134	112	18	106	11x17x11,1	25	-13	7550	20000	4920

► **LMHP SOROZAT / LMHP SERIES / SERIA LMHP**

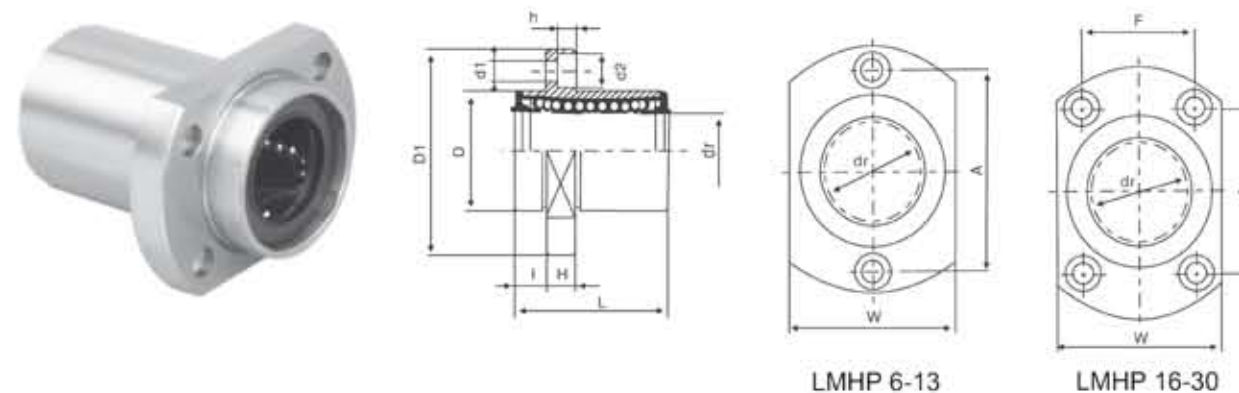

Típus Type Tipul	Golyó sorok Ball circuit Circuitul de bile	dr		D		L (±0,3)	I	D1	W	H	A	F	D1xd2xh	Excent- rikusság Eccentrici- tate (max.) (µm)	Terhelés Load Sarcina (N)		Tömeg Weight Masa (g)
		(mm)	(µm)	(mm)	(µm)										C	C0	
LMHP6UU	4	6		12	0	19	5	28	18	5	20	-	3,5x6x3,1	12	206	265	21
LMHP8UU	4	8		15	-13	24	5	32	21	5	24	-	3,5x6x3,1	12	274	392	33
LMHP10UU	4	10	0	19		29	6	40	25	6	29	-	4,5x7,5x4,1	12	372	549	64
LMHP12UU	4	12	-9	21	0	30	6	42	27	6	32	-	4,5x7,5x4,1	12	510	784	68
LMHP13UU	4	13		23	-16	32	6	43	29	6	33	-	4,5x7,5x4,1	12	510	784	81
LMHP16UU	5	16		28		37	6	48	34	6	31	22	4,5x7,5x4,1	12	774	1180	112
LMHP20UU	5	20		32		42	8	54	38	8	36	24	5,5x9x5,1	15	882	1370	167
LMHP25UU	6	25	0	40	0	59	8	62	46	8	40	32	5,5x9x5,1	15	980	1570	325
LMHP30UU	6	30	-10	45	-19	64	10	74	51	10	49	35	6,6x11x6,1	15	1570	2740	388

LINEÁRIS TENGELYEK ÉS CSAPÁGYAK  
LINEAR SHAFTS AND BALL BUSHINGS  
AXE SI RULMENTI LINIARI

LMHP\_L SOROZAT / LMHP\_L SERIES / SERIA LMHP\_L

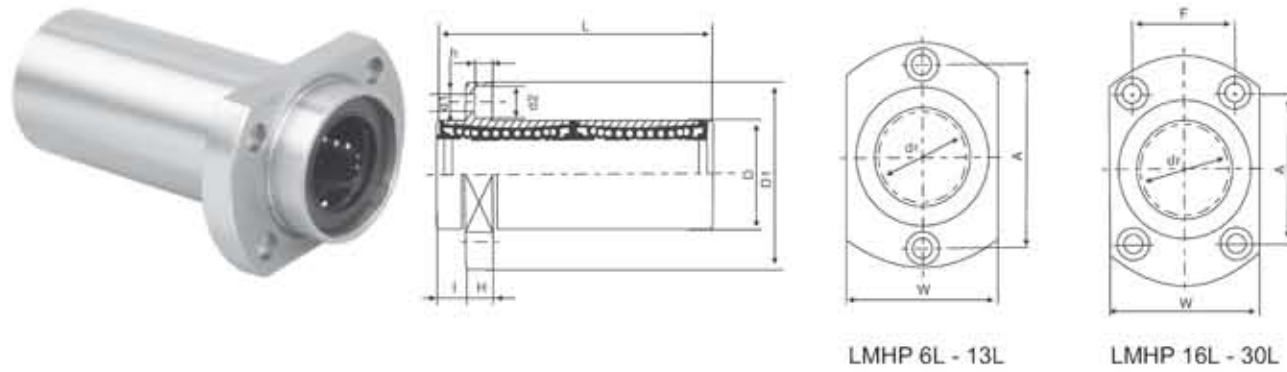

Tipus Type Tipul	Golyó sorok Ball circuit Circuitul de bile	dr		D		L (±0,3)	I	D1	W	H	A	F	D1xd2xh	Excent- rikusság Eccentricity Excentrici- tate (max.) (N)	Terhelés Load Sarcina		Tömeg Weight Masa (mm)
		(mm)	(µm)	(mm)	(µm)										C	C0	
LMHP6LUU	4	6		12	0	35	5	28	18	5	20	-	3,5x6x3,1	15	323	529	28
LMHP8LUU	4	8		15	-13	45	5	32	21	5	24	-	3,5x6x3,1		431	784	47
LMHP10LUU	4	10	0	19		55	6	40	25	6	29	-	4,5x7,5x4,1		588	1100	90
LMHP12LUU	4	12	-10	21	0	58	6	42	27	6	32	-	4,5x7,5x4,1		813	1570	102
LMHP13LUU	4	13		23	-16	61	6	43	29	6	33	-	4,5x7,5x4,1		813	1570	123
LMHP16LUU	5	16		28		70	6	48	34	6	31	22	4,5x7,5x4,1		1230	2350	182
LMHP20LUU	5	20		32		80	8	54	38	8	36	24	5,5x9x5,1	1400	2740	247	
LMHP25LUU	6	25	0	40	0	112	8	62	46	8	40	32	5,5x9x5,1	20	1560	3140	525
LMHP30LUU	6	30	-12	45	-19	123	10	74	51	10	49	35	6,6x11x6,1		2490	5490	645

LINEÁRIS TENGELYEK ÉS CSAPÁGYAK  
LINEAR SHAFTS AND BALL BUSHINGS  
AXE SI RULMENTI LINIARI

LMKP SOROZAT / LMKP SERIES / SERIA LMKP

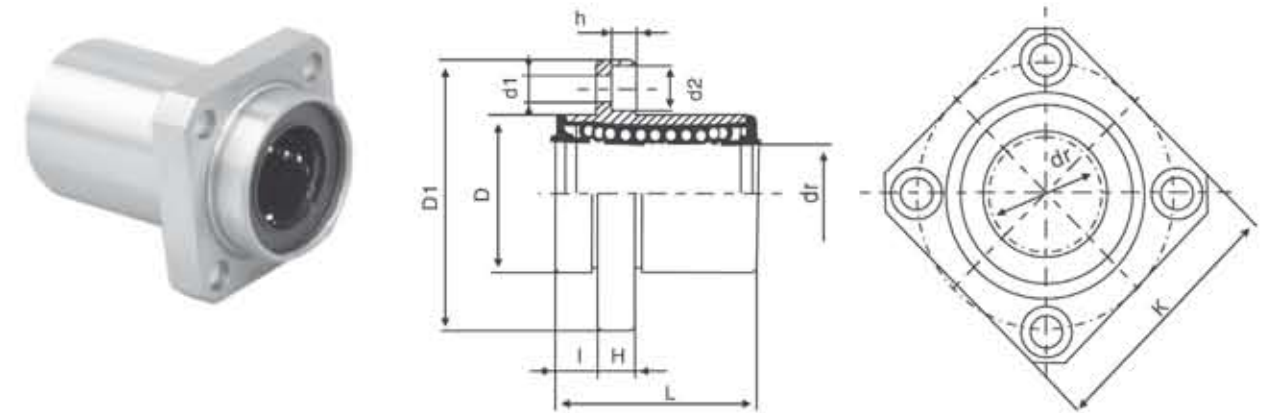

Tipus Type Tipul	Golyó sorok Ball circuit Circuitul de bile	dr		D		L (±0,3)	I	D1	K	H	PCD	d1xd2xh	Excent- rikusság Eccentricity Excentrici- tate (max.) (N)	Terhelés Load Sarcina		Tömeg Weight Masa (g)
		(mm)	(µm)	(mm)	(µm)									C	C0	
LMKP6UU	4	6		12	0	19	5	28	22	5	20	3,5x6x3,1	12	206	265	24
LMKP8UU	4	8		15	-13	24	5	32	25	5	24	3,5x6x3,1		274	392	37
LMKP10UU	4	10	0	19		29	6	40	30	6	29	4,5x7,5x4,1		372	549	72
LMKP12UU	4	12	-9	21	0	30	6	42	32	6	32	4,5x7,5x4,1		510	784	76
LMKP13UU	4	13		23	-16	32	6	43	34	6	33	4,5x7,5x4,1		510	784	88
LMKP16UU	5	16		28		37	6	48	37	6	38	4,5x7,5x4,1		774	1180	120
LMKP20UU	5	20		32		42	8	54	42	8	43	5,5x9x5,1	882	1370	180	
LMKP25UU	6	25	0	40	0	59	8	62	50	8	51	5,5x9x5,1	15	980	1570	340
LMKP30UU	6	30	-10	45	-19	64	10	74	58	10	60	6,6x11x6,1		1570	2740	470
LMKP35UU	6	35		52		70	10	82	64	10	67	6,6x11x6,1	1670	3140	650	
LMKP40UU	6	40	0	60	0	80	13	96	75	13	78	9x14x8,1	20	2160	4020	1060
LMKP50UU	6	50	-12	80	-22	100	13	116	92	18	98	9x14x8,1		3820	7940	2200
LMKP60UU	6	60	0/-15	90	0/-25	110	18	134	106	18	112	11x17x11,1	25	4700	10000	3000

LINEÁRIS TENGELYEK ÉS CSAPÁGYAK  
LINEAR SHAFTS AND BALL BUSHINGS  
AXE SI RULMENTI LINIARI

LMKP\_L SOROZAT / LMKP\_L SERIES / SERIA LMKP\_L

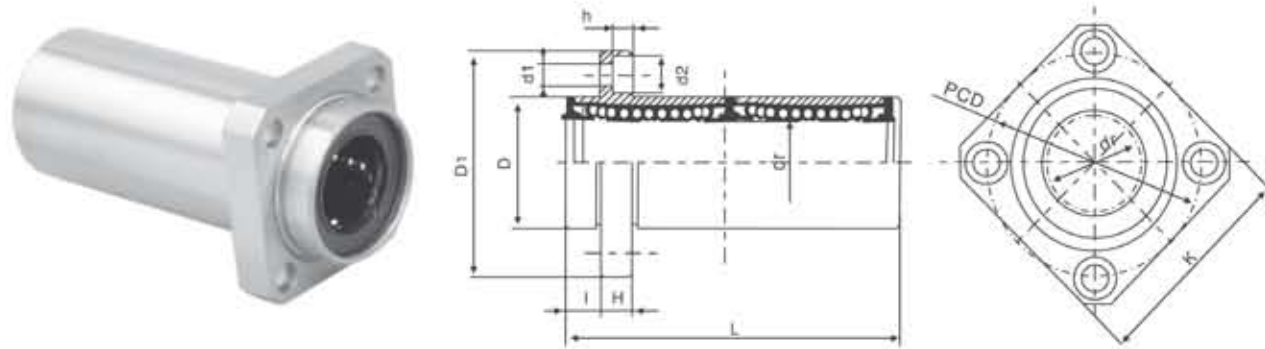

Típus Type Tipul	Golyó sorok Ball circuit Circuitul de bile	dr		D		L (±0,3)	I	D1	K	H	PCD	d1xd2xh	Excentrikusság Eccentricity Excentricitate (max.)	Terhelés Load Sarcina		Tömeg Weight Masa
		(mm)	(µm)	(mm)	(µm)									C	C0	
LMKP6LUU	4	6		12	0	35	5	28	22	5	20	3,5x6x3,1	15	323	529	31
LMKP8LUU	4	8		15	-13	45	5	32	25	5	24	3,5x6x3,1		431	784	51
LMKP10LUU	4	10	0	19		55	6	40	30	6	29	4,5x7,5x4,1		588	1100	98
LMKP12LUU	4	12	-10	21	0	57	6	42	32	6	32	4,5x7,5x4,1	813	1570	110	
LMKP13LUU	4	13		23	-16	61	6	43	34	6	33	4,5x7,5x4,1	813	1570	130	
LMKP16LUU	5	16		28		70	6	48	37	6	38	4,5x7,5x4,1	1230	2350	190	
LMKP20LUU	5	20		32		80	8	54	42	8	43	5,5x9x5,1	1400	2740	260	
LMKP25LUU	6	25	0	40	0	112	8	62	50	8	51	5,5x9x5,1	20	1560	3140	540
LMKP30LUU	6	30	-12	45	-19	123	10	74	58	10	60	6,6x11x6,1	2490	5490	680	
LMKP35LUU	6	35		52		135	10	82	64	10	67	6,6x11x6,1	2650	6270	1020	
LMKP40LUU	6	40	0	60	0	151	13	96	75	13	78	9x14x8,1	25	3430	8040	1570
LMKP50LUU	6	50	-15	80	-22	192	13	116	92	18	98	9x14x8,1	6080	15900	3600	
LMKP60LUU	6	60	0/-20	90	0/-25	209	18	134	106	18	112	11x17x11,1	7550	20000	4500	

LINEÁRIS TENGELYEK ÉS CSAPÁGYAK  
LINEAR SHAFTS AND BALL BUSHINGS  
AXE SI RULMENTI LINIARI

LMEKC SOROZAT / LMEKC SERIES / SERIA LMEKC

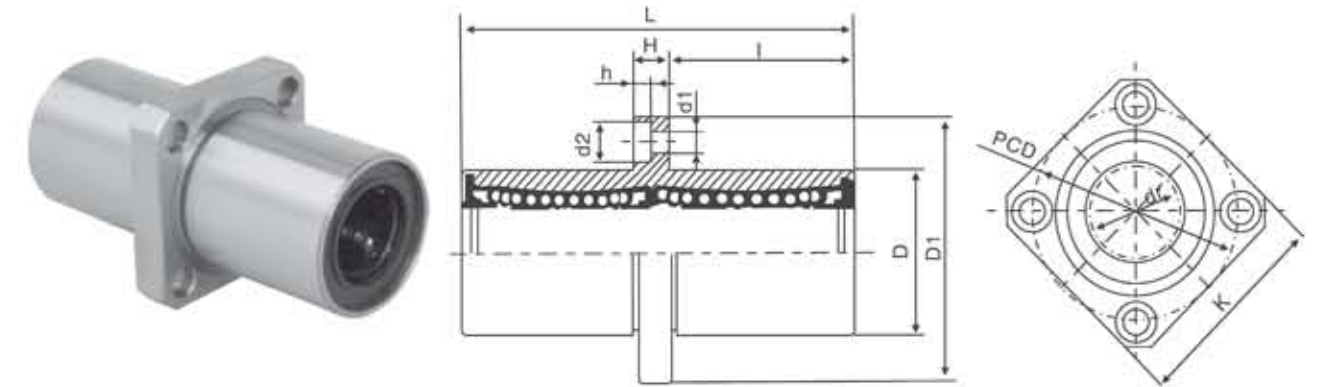

Típus Type Tipul	Golyó sorok Ball circuit Circuitul de bile	dr		D		L (±0,3)	I	D1	K	H	PCD	d1xd2xh	Excentrikusság Eccentricity Excentricitate (max.)	Terhelés Load Sarcina		Tömeg Weight Masa
		(mm)	(µm)	(mm)	(µm)									C	C0	
LMEKC8UU	4	8	+9	16	0/-13	46	20,5	32	25	5	24	3,5x6x3,1	15	431	804	59
LMEKC12UU	4	12	-1	22		61	27,5	42	32	6	32	4,5x7,5x4,1		813	1570	110
LMEKC16UU	5	16	+11	26		68	31	46	35	6	38	4,5x7,5x4,1		921	1780	160
LMEKC20UU	5	20	-1	32	0	80	36	54	42	8	43	5,5x9x5,1	1370	2740	260	
LMEKC25UU	6	25	+13	40	-19	112	52	62	50	8	51	5,5x9x5,1	17	1570	3140	540
LMEKC30UU	6	30	-2	47		123	56,5	76	60	10	62	6,6x11x6,1	2500	5490	815	
LMEKC40UU	6	40		62	0	151	69	98	75	13	80	9x14x8,1	20	3430	8040	1805
LMEKC50UU	6	50	+16	75	-22	192	89,5	112	88	18	94	9x14x8,1	6080	15900	2820	
LMEKC60UU	6	60	-4	90	0/-25	209	95,5	134	106	18	112	11x17x11,1	25	7550	20000	4920

LINEÁRIS TENGELYEK ÉS CSAPÁGYAK  
LINEAR SHAFTS AND BALL BUSHINGS  
AXE SI RULMENTI LINIARI

▼ SBE SOROZAT / SBE SERIES / SERIA SBE

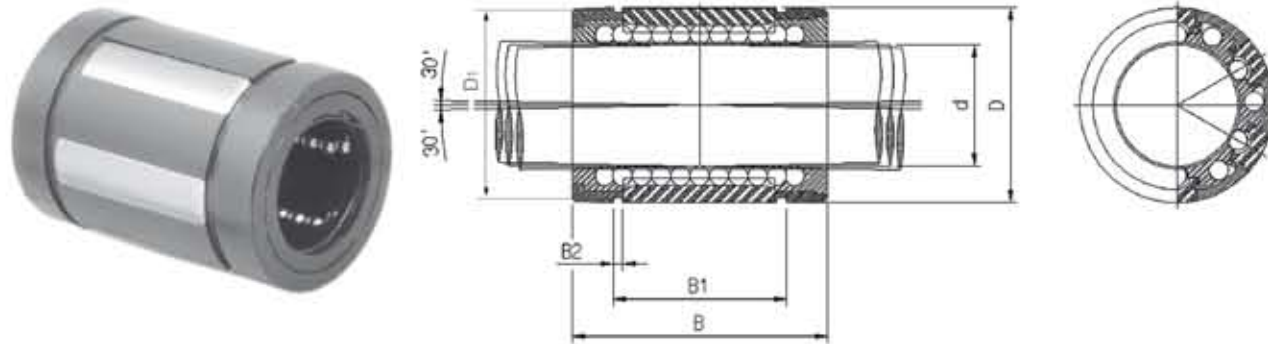

Típus Type Tipul	Golyó sorok Ball circuit Circuitul de bile	d	D	F1	B	B1	B2	Terhelés Load Sarcina	
								C	C0
								(mm)	
SBE 16UU	5	16	26	24,9	036	24,6	1,3	1176	607
SBE 20UU	6	20	32	30,5	045	31,2	1,6	2352	1254
SBE 25UU	6	25	40	38,5	058	43,7	1,85	4508	2195
SBE 30UU	6	30	47	44,5	068	51,7	1,85	5586	2959
SBE 40UU	6	40	62	58,5	080	60,3	2,15	9310	4312
SBE 50UU	6	50	75	71,5	100	77,3	2,65	13720	6762

LINEÁRIS TENGELYEK ÉS CSAPÁGYAK  
LINEAR SHAFTS AND BALL BUSHINGS  
AXE SI RULMENTI LINIARI

▼ FMTC SOROZAT / FMTC SERIES / SERIA FMTC

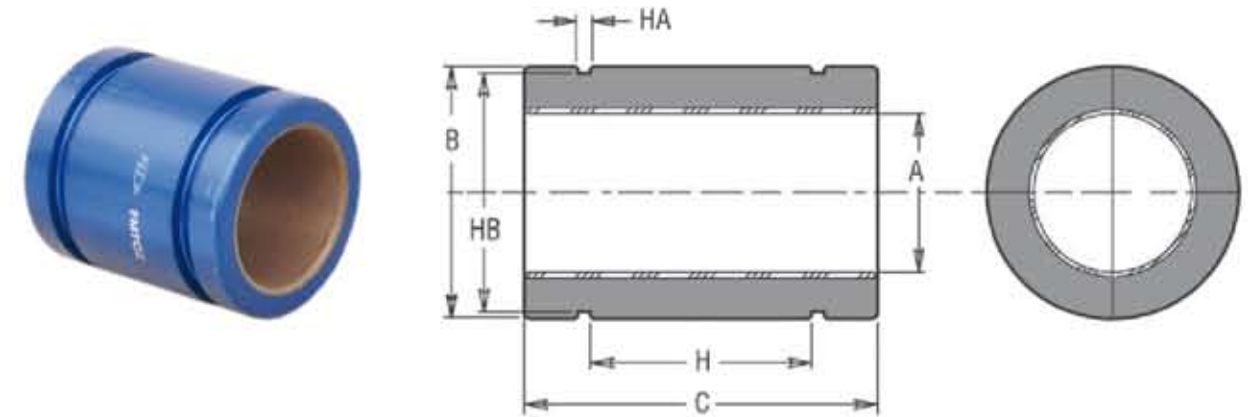

Típus Type Tipul	A		B		C		Koncentrikusság Concentricity Concentricitate	H	HA	HB	Terhelés Load Sarcina	Tömeg Weight Masa
	min	max	min	max	min	max						
	(mm)											
FMTC 06	6,060	6,078	11,982	12	21,746	22	0,0254	-	-	-	2727	6
FMTC 08	8,063	8,085	14,982	15	23,746	24	0,0254	10	2	12,2	3963	8
FMTC 10	10,063	10,085	16,982	17	25,746	26	0,0254	12	2	14,4	5356	9
FMTC 12	12,066	12,093	18,979	19	27,746	28	0,0254	14	2	16,6	6926	12
FMTC 14	14,066	14,093	20,979	21	27,746	28	0,0254	14	2	18,5	8083	13
FMTC 16	16,066	16,093	23,979	24	29,746	30	0,0254	14	2	21,3	9888	19
FMTC 20	20,096	20,129	27,979	28	29,746	30	0,0254	14	2	25,5	12361	23
FMTC 25	25,096	25,129	34,975	35	39,746	40	0,0254	22	3,2	30,9	20601	44
FMTC 30	30,090	30,129	39,975	40	49,746	30	0,0254	30	3,2	35,9	30902	65
FMTC 40	40,127	40,166	51,970	52	59,746	60	0,0254	40	4,1	46,2	49442	123
FMTC 50	50,127	50,133	61,970	62	69,746	70	0,0254	50	4,1	56,3	72104	178

Kivitele / construction / forma constructiva: siklócsapágy / plain bearing / lagar de alunecare

Anyaga / material / material: eloxált alumínium / anodized aluminium / aluminiu eloxat

Belső bevonata / internal coating / invelis interior: teflon / teflon / teflon



Forgó lineáris csapágyak méretválasztéka / Rotary bushes sizes /  
Rulmenti liniari rotativi

FORGÓ CSAPÁGY TECHNIKAI LEÍRÁSA / TECHNICAL INFORMATION ABOUT  
ROTARY BUSH / INFORMATII TEHNICE DESPRE AXE SI RULMENTI ROTATIVI

**A forgó csapágyról**

Ez a típusú csapágy a lineáris és rotációs mechanizmus felhasználásával képes forgó mozgást végezni a benne lévő golyók segítségével a külső gyűrű és egy tengely között. (4. ábra) Ez a kompakt megoldás ellenáll a nagy terhelésnek. A golyókosár nagy kopásállóságú könnyűfém ötvözetből készült. Síma mozgás mellett nagy sebesség és nagy gyorsulás érhető el. Működési hőmérséklet tartománya -20 °C + 110 °C.

**About rotary bush**

This bush is a linear and rotational motion mechanism utilizing the rotational motion of ball elements between an outer cylinder and a shaft. (Fig. 4.) It is compact and can withstand high loading. The retainer is made of a light metal alloy with high wear resistance. Smooth motion is achieved under high-speed and high acceleration conditions. Working temperature is -20 °C + 110 °C.

**Despre rulmenti rotativi**

Acest rulment executa atat o miscare liniara cat si o miscare de rotatie, utilizand bile aflate intr-un cilindru exterior. (fig4.) Este compact si poate suporta sarcini ridicate. Opritorul este dintr-un aliaj de metale usoare cu o rezistenta mare la uzura. Miscarea lina este asigurata si la viteze si acceleratii mari. Temperatura de lucru este intre -20 °C + 110 °C.

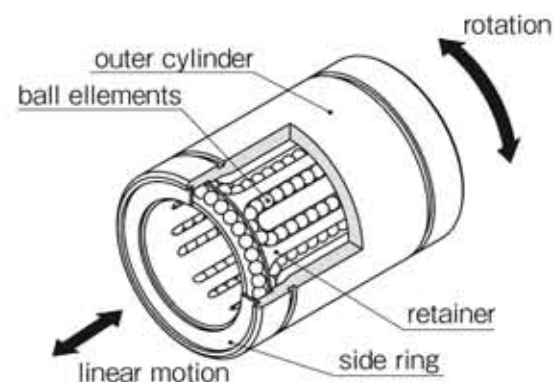

4. ábra. Forgó csapágy működési elve  
Fig. 4. Structure of Slide Rotary Bush  
Fig.4. Structura rulmentului liniar rotativ

BEÉPÍTÉSI PÉLDÁK / APPLICATION EXAMPLE / EXEMPLE DE APLICATII:

5. ábra Fügőleges robot kar  
Fig. 5. Vertical robot arm  
Fig. 5. Brat robotizat vertical

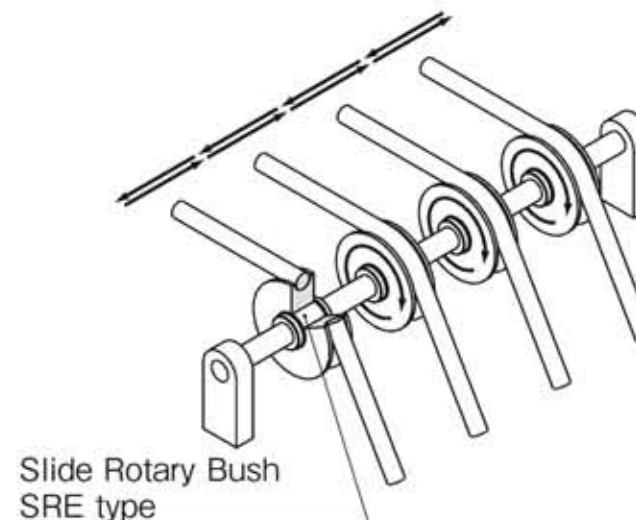
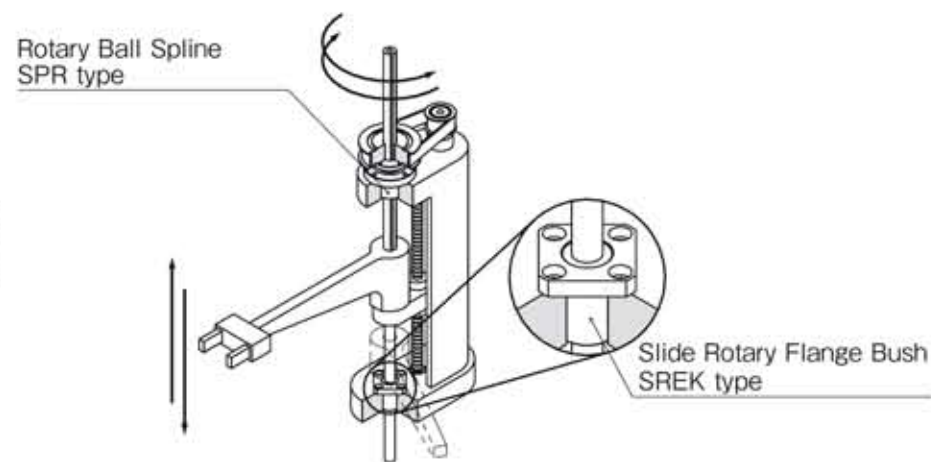

5. ábra Feszítő görgők  
Fig. 5. Multiple gearing idler  
Fig 5. Roti de tensionare

5. ábra Forgó asztal  
Fig. 5. Turn table  
Fig. 5. Masa rotativa

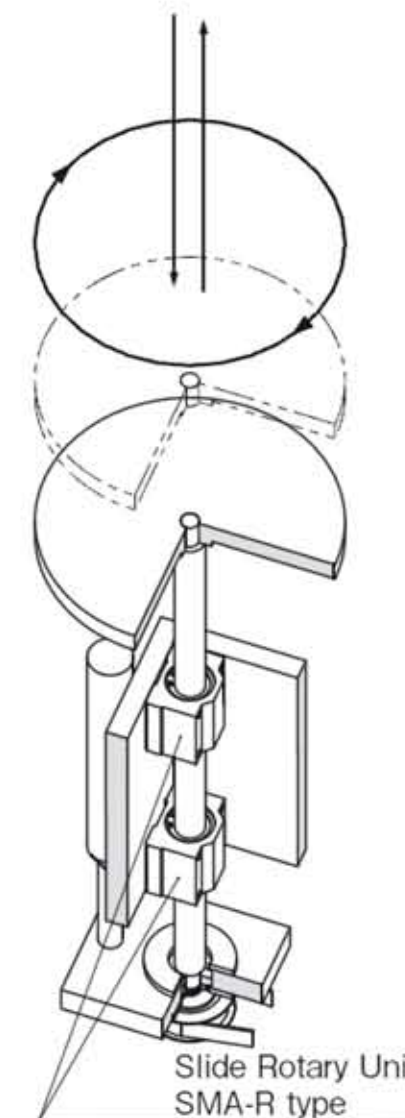

SR SOROZAT (FORGÓ CSAPÁGY) / SR SERIES (ROTARY BUSH) /  
SERIA SR (RULMENTI ROTATIVI)

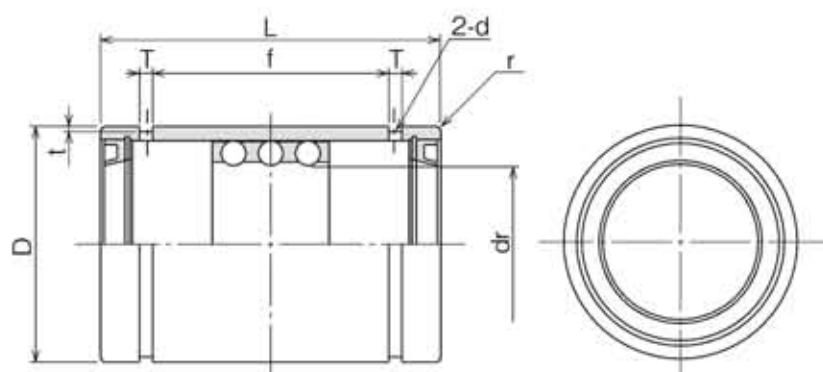

Típus Type Tipul	Max. löket Max. stroke Cursa maxima	Golyó sorok Ball circuit Circuite de bile	dr		D		L		f	T	t	d	r	Terhelés Load Sarcina		Tömeg Weight Masa
			min	max	min	max	min	max						C	C0	
			(mm)													
SR 8UU	14	3	8	+22 / +13	15	0 / -11	24		12,3	1,5	0,5	1,2	0,5	343	245	15,6
SR 10UU	16	3	10		19	30	15,5		1,5	0,5	1,2	0,5	637	461	28,8	
SR 12UU	18	3	12	+27 / +16	23	0 / -13	32	0 / -0,2	17,1	1,5	0,5	1,2	0,5	1070	813	42
SR 16UU	26	3	16		28	37	21,1	1,5	0,7	1,3	0,5	1180	990	71		
SR 20UU	36	3	20	+33 / +20	32		45		26,8	2	0,7	1,5	0,5	1260	1170	99
SR 25UU	36	3	25		37	0 / -16	45		26,8	2	0,7	1,6	1	1330	1330	117
SR 30UU	68	3	30	+41 / +25	45		65	0 / -0,3	45,1	2,5	1	2	1	2990	3140	205
SR 35UU	76	3	35		52	70	50,1		2,5	1	2	1,5	3140	3530	329	
SR 40UU	91	3	40	+49 / +30	60	0 / -19	80	0 / -0,4	59,9	2,5	1	2	1,5	4120	4800	516
SR 50UU	116	3	50		72	100	77,4		3	1	2,5	1,5	5540	6910	827	
SR 60UU	117	3	60	+58 / +36	85	0 / -22	100		77,4	3	1	2,5	2	5980	8230	1240
SR 80UU	110	3	80		110	100	77		3	1,5	2,5	2	7840	12200	2050	
SR100UU	110	3	100		130	0 / -25	100		77	3	1,5	2,5	2	8430	14700	2440

SRE SOROZAT (FORGÓ CSAPÁGY) / SRE SERIES (ROTARY BUSH) /  
SERIA SRE (RULMENTI ROTATIVI)

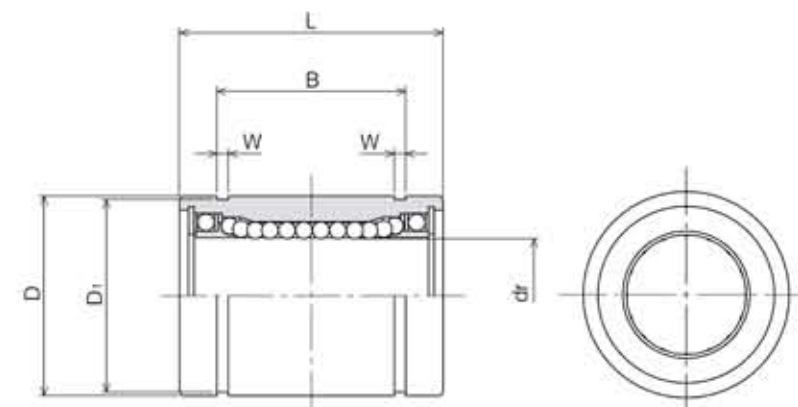

Típus Type Tipul	Max. fordulát Max. rev. Turatia maxima	dr	D	L	B	W	D1	Terhelés Load Sarcina		Tömeg Weight Masa		
								C	C0			
								1/min (mm) (N) (N) (g)				
SRE 6	300	6	12	19	13,5	1,1	11,5	78	176	10		
SRE 8	300	8	15	0 / -11	24	17,5	1,1	14,3	137	314	20	
SRE 10	300	10	19		29	22	1,3	18	157	372	39	
SRE 12	300	12	21	0 / -0,2	30	23	0 / -0,2	1,3	20	274	588	42
SRE 13	300	13	23	0 / -13	32	23	1,3	22	323	686	56	
SRE 16	250	16	28		37	26,5	1,6	27	451	882	97	
SRE 20	250	20	32		42	30,5	1,6	30,5	647	1180	133	
SRE 25	250	25	40	0 / -16	59	41	1,85	38	882	1860	293	
SRE 30	250	30	45	0 / -0,3	64	44,5	0 / -0,3	1,85	43	1180	1650	371
SRE 40	250	40	60	0 / -19	80	60,5	2,1	57	1960	4020	778	

► **SREK SOROZAT (FORGÓ CSAPÁGY) / SREK SERIES (ROTARY BUSH) /  
SERIA SREK (RULMENTI ROTATIVI)**

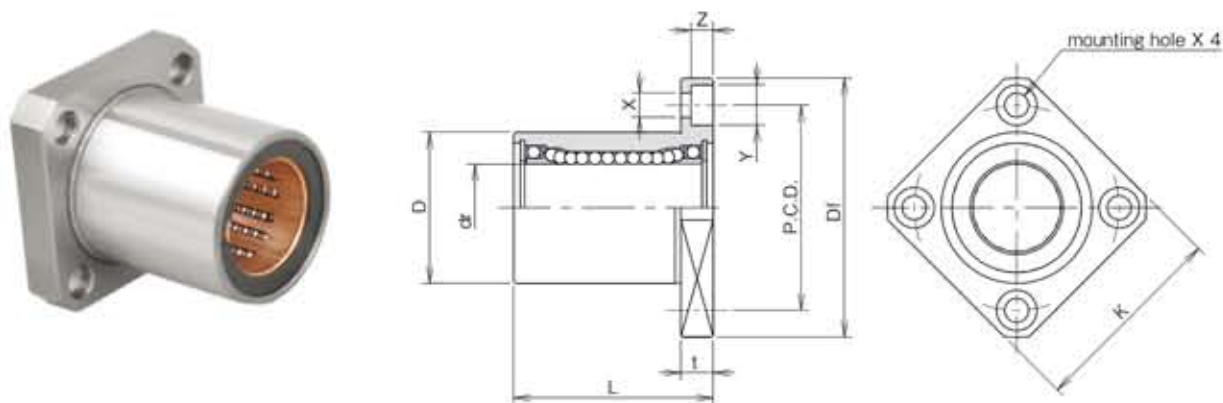

Típus Type Tipul	Max. fordulat Max. rev. Turatia maxima	dr	D	L (±0,3)	Df	K	t	P.C.D.	X x Y x Z	Terhelés Load Sarcina		Tömeg Weight Masa	
										C	C0		
										(N)	(N)		(g)
SREK 6	300	6	12	0/-13	19	28	22	5	20	3,5x6x3,1	78	176	21
SREK 8	300	8	15		24	32	25	5	24		137	314	33
SREK 10	300	10	19	0/-16	29	40	30	6	29	4,5x7,5x4,1	157	372	61
SREK 12	300	12	21		30	42	32	6	32		274	588	67
SREK 13	300	13	23		32	43	34	6	33		323	686	83
SREK 16	250	16	28		37	48	37	6	38		451	882	126
SREK 20	250	20	32	0/-19	42	54	42	8	43	5,5x9x5,1	647	1180	178
SREK 25	250	25	40		59	62	50	8	51		882	1860	355
SREK 30	250	30	45		64	74	58	10	60		1180	1650	483

► **SMA-R SOROZAT (FORGÓ CSAPÁGY HÁZZAL) / SMA-R SERIES (ROTARY  
BUSH WITH HOUSING) / SERIA SMA-R (RULMENTI ROTATIVI CU CARCASA)**

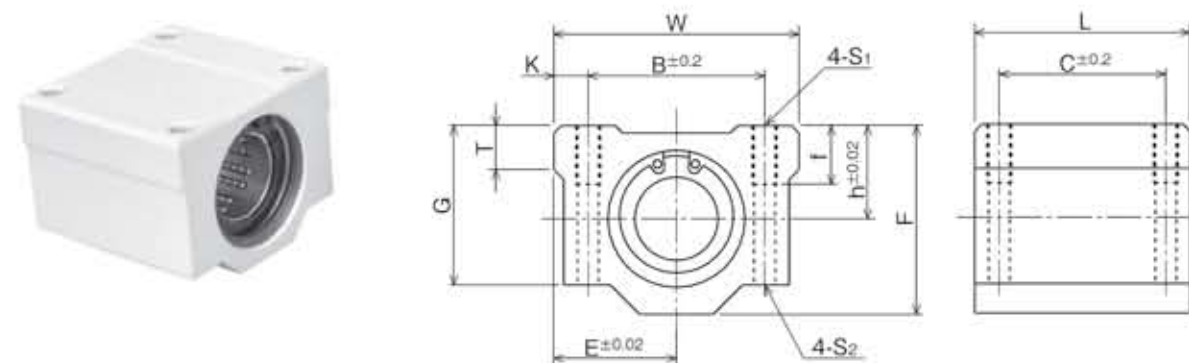

Típus Type Tipul	Max. fordulat Max. rev. Turatia maxima	Tengely Ø Shaft Ø Ø Ax	h	e	w	L	F	G	T	B	C	K	S1	F	S2	Terhelés Load Sarcina		Tömeg Weight Masa
																C	C0	
																(N)	(N)	
SMA 6R	300	6	9	15	30	25	18	15	6	20	15	5	M4	8	3,4	78	176	33
SMA 8R	300	8	11	17	34	30	22	18	6	24	18	5	M4	8	3,4	137	314	55
SMA 10R	300	10	13	20	40	35	26	21	8	28	21	6	M5	12	4,3	157	372	93
SMA 12R	300	12	15	21	42	36	28	24	8	30,5	26	5,75	M5	12	4,3	274	588	104
SMA 13R	300	13	15	22	44	39	30	24,5	8	33	26	5,5	M5	12	4,3	323	686	128
SMA 16R	250	16	19	25	50	44	38,5	32,5	9	36	34	7	M5	12	4,3	451	882	216
SMA 20R	250	20	21	27	54	50	41	35	11	40	40	7	M6	12	5,2	647	1180	286
SMA 25R	250	25	26	38	76	67	51,5	42	12	54	50	11	M8	18	7	882	1860	645
SMA 30R	200	30	30	39	78	72	59,5	49	15	58	58	10	M8	18	7	1180	2650	824
SMA 40R	200	40	40	51	102	90	78	62	20	80	60	11	M10	25	8,7	1960	4020	1719

Lineáris csúszkák méretválasztéka / Linear housing units sizes /  
Dimensiunile axelor si ai rulmentilor liniari



▼ **KBA\_S** SOROZAT (EURÓPAI SZABVÁNY) / **KBA\_S** SERIES (EUROPE SERIES) /  
**SERIA KBA\_S** (SERIE EUROPEANA)

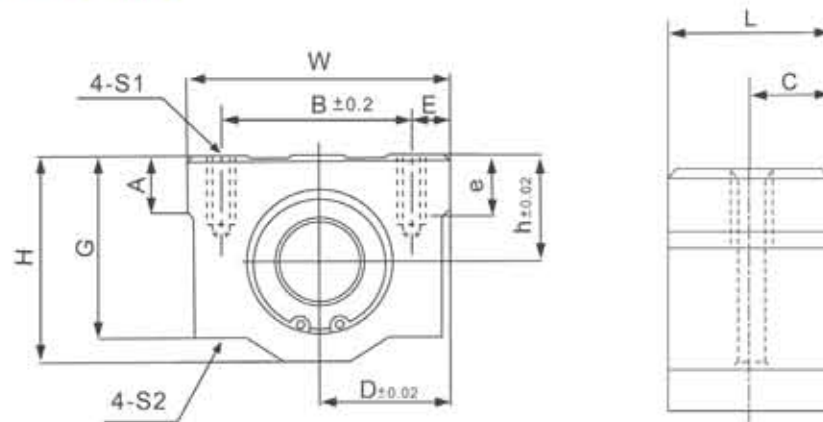

Típus Type Tipul	h	D	W	H	G	A	B	E	S1xE	S2	C	L	Terhelés Load Sarcina		Tömeg Weight Masa
													C	C0	
													(mm)		
KBA8SUU	11	17	34	22	18	6	24	5	M4X8	3,4	7,2	14,4	274	392	25
KBA12SUU	15	22	44	30	24,5	8	33	5,5	M5X12	4,3	10,4	20,8	510	784	65
KBA16SUU	19	25	50	38,5	32,5	9	36	7	M5X12	4,3	11,2	22,4	774	1180	100
KBA20SUU	21	27	54	41	35	11	40	7	M6X12	5,2	14,5	29	882	1370	148
KBA25SUU	26	38	76	51,5	42	12	54	11	M8X18	7	20,45	40,9	980	1570	368
KBA30SUU	30	39	78	59,5	49	15	58	10	M8X18	7	24,45	48,9	1574	2740	500
KBA40SUU	40	51	102	78	62	20	80	11	M10X25	8,7	28,2	56,4	2160	4020	1000
KBA50SUU	52	61	122	102	80	25	100	11	M10X25	8,7	36,2	72,4	3820	7940	2205

▼ **KBA** SOROZAT (EURÓPAI SZABVÁNY) / **KBA** SERIES (EUROPE SERIES) /  
**SERIA KBA** (SERIE EUROPEANA)

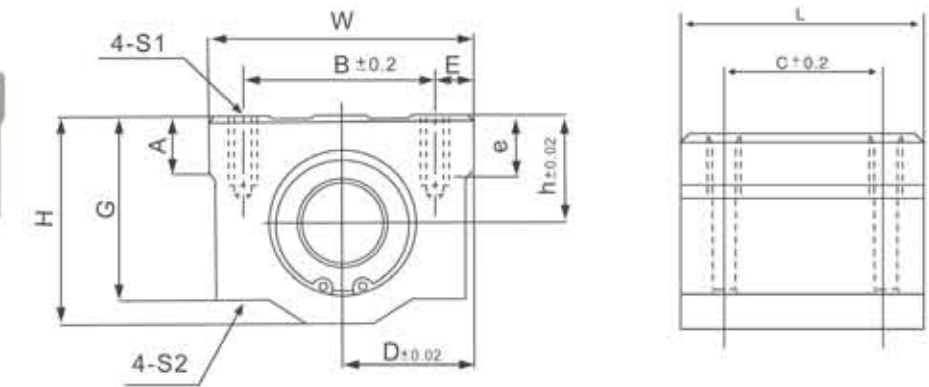

Típus Type Tipul	Tengely Ø Shaft Ø Ø Ax	h	D	W	L	F	G	T	B	C	E	S1xe	S2	Tömeg Weight Masa															
															(mm)														(g)
KBA10UU	10	13	20	40	35	26	21	8	28	21	6	M5x12	4,3	92															
KBA12UU	12	15	22	44	39	30	24,5	8	33	26	5,5	M5x12	4,3	120															
KBA16UU	16	19	25	50	44	38,5	32,5	9	36	34	7	M5x12	4,3	200															
KBA20UU	20	21	27	54	53	41	35	11	40	40	7	M6x12	5,2	270															
KBA25UU	25	26	38	76	67	51,5	42	12	54	50	11	M8x18	7	600															
KBA30UU	30	30	39	78	76	59,5	49	15	58	58	10	M8x18	7	776															
KBA40UU	40	40	51	102	90	78	62	20	80	60	11	M10x25	8,7	1590															
KBA50UU	50	52	61	122	110	102	80	25	100	80	11	M10x25	8,7	3340															
KBA60UU	60	58	66	132	137	114	94	30	108	90	12	M12x25	10,7	4800															

LINEÁRIS TENGELEK ÉS CSAPÁGYAK  
LINEAR SHAFTS AND BALL BUSHINGS  
AXE SI RULMENTI LINIARI

▼ **KBA\_L SOROZAT (EURÓPAI SZABVÁNY) / KBA\_L SERIES (EUROPE SERIES) /  
SERIA KBA\_L (SERIA EUROPEANA)**

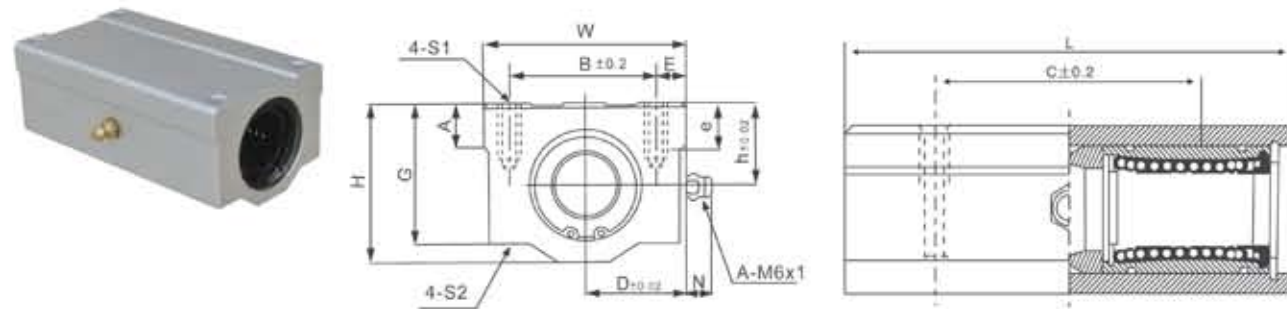

Típus Type Tipul	Tengely Ø Shaft Ø Ø Ax	h	D	W	L	F	G	T	B	C	E	S1xe	S2	Tömeg Weight Masa
KBA10LUU	10	13	20	40	68	26	21	8	28	46	6	M5x12	4,3	180
KBA12LUU	12	15	22	44	77	30	24,5	8	33	64	5,5	M5x12	4,3	237
KBA16LUU	16	19	25	50	89	38,5	32,5	9	36	79	7	M5x12	4,3	405
KBA20LUU	20	21	27	54	100	41	35	11	40	90	7	M6x12	5,2	510
KBA25LUU	25	26	38	76	136	51,5	42	12	54	119	11	M8x18	7	1220
KBA30LUU	30	30	39	78	154	59,5	49	15	58	132	10	M8x18	7	1580
KBA40LUU	40	40	51	102	180	78	62	20	80	150	11	M10x25	8,7	3180
KBA50LUU	50	52	61	122	230	102	80	25	100	200	11	M10x25	8,7	6990

LINEÁRIS TENGELEK ÉS CSAPÁGYAK  
LINEAR SHAFTS AND BALL BUSHINGS  
AXE SI RULMENTI LINIARI

▼ **SMCC SOROZAT / SMCC SERIES / SERIA SMCC**

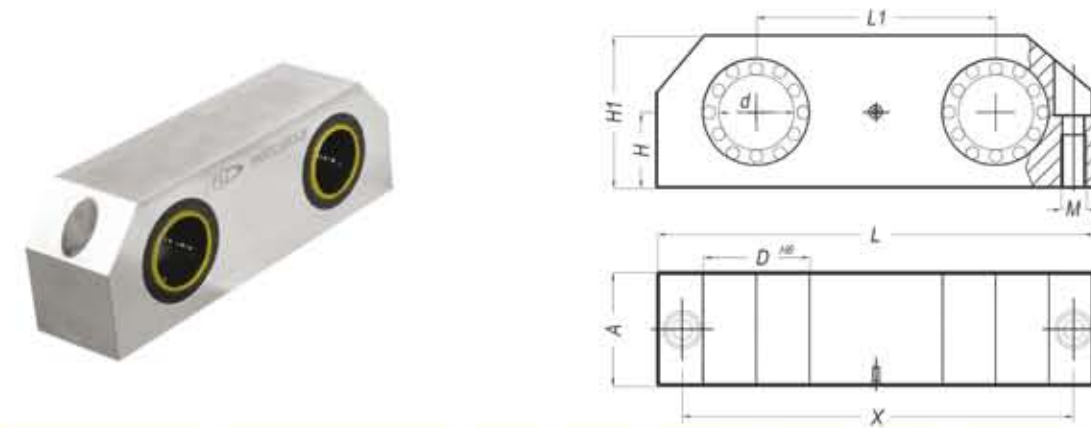

Típus Type Tipul	Tengely Ø Shaft Ø Ø Ax	A	H	H1	L	L1	M	Tömeg Weight Masa
SMCC12	12	28	15	30	80	40	M5	188
SMCC16	16	30	17,5	35	96	52	M5	256
SMCC20	20	30	20	40	115	63	M6	316
SMCC25	25	40	25	50	136	75	M8	632
SMCC30	30	50	28	56	146	80	M8	890
SMCC40	40	60	35	70	184	97	M10	1660
SMCC50	50	70	40	80	210	107	M12	2250

LINEÁRIS TENGELEK ÉS CSAPÁGYAK  
LINEAR SHAFTS AND BALL BUSHINGS  
AXE SI RULMENTI LINIARI

► SMLC SOROZAT / SMLC SERIES / SERIA SMLC

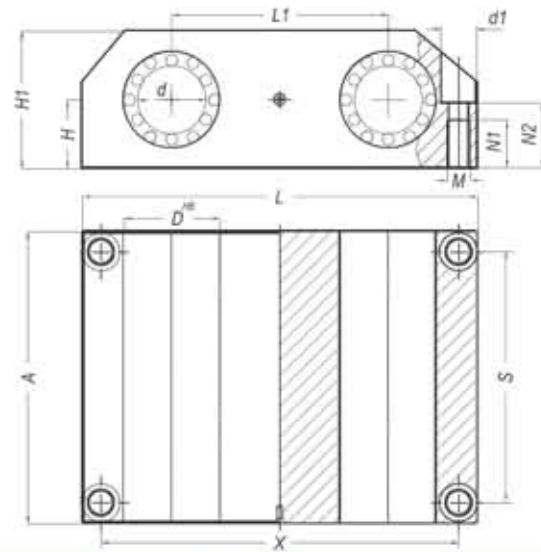

Típus Type Tipul	Tengely Ø Shaft Ø Ø Ax	(mm)							Tömeg Weight Masa (g)
		A	H	H1	L	L1	M		
SMLC12	12	70	15	30	80	40	M5	376	
SMLC16	16	80	17,5	35	96	52	M5	612	
SMLC20	20	85	20	40	115	63	M6	832	
SMLC25	25	100	25	50	136	75	M8	1464	
SMLC30	30	130	28	56	146	80	M8	2180	
SMLC40	40	150	35	70	184	97	M10	3820	
SMLC50	50	175	40	80	210	107	M12	5500	

LINEÁRIS TENGELEK ÉS CSAPÁGYAK  
LINEAR SHAFTS AND BALL BUSHINGS  
AXE SI RULMENTI LINIARI

Talpas tengelyek és csapágyak méretválasztéka / Slide units and bushing sizes /  
Dimensiunile axelor si ai rulmentilor liniari cu talpa

► SA TALPAS TENGELEK / SA SLIDE UNIT / AX SA CU TALPA

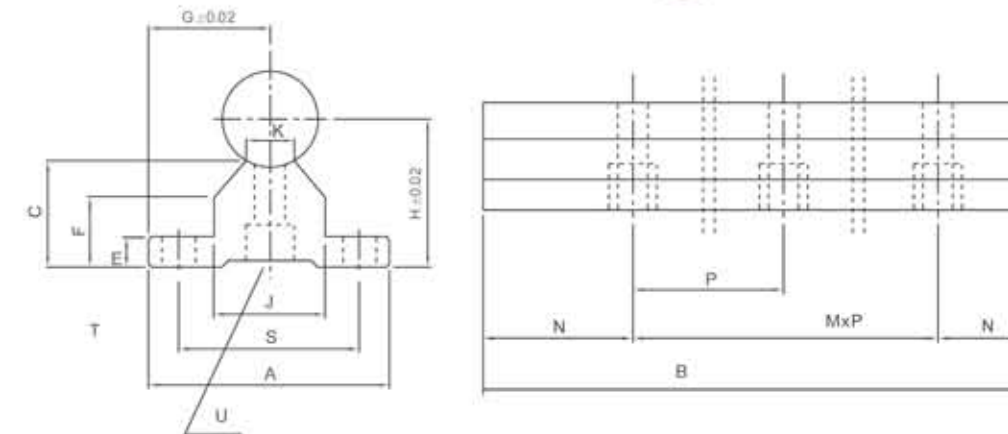

Típus Type Tipul	Tengely Ø Shaft Ø Ø Ax	(mm)														Tömeg Weight Masa (kg/m)
		H	G	A	B (max)	C	E	F	J	K	L	P	S	T	U	
SA16	16	25	20	40	4000	17,8	5	11,7	18,5	8	80°	150	30	5,5	M5	1
SA20	20	27	22,5	45	4000	17,7	5	10	19	8	50°	150	30	5,5	M6	1,2
SA25	25	33	27,5	55	4000	21	6	12	21,5	8	50°	200	35	6,5	M6	1,46
SA30	30	37	30	60	4000	22,8	7	13	26,5	13	50°	200	40	6,5	M8	1,84
SA35	35	43	32,5	65	4000	26,5	8	15,5	28	13	50°	200	45	9	M8	2,38

LINEÁRIS TENGELEK ÉS CSAPÁGYAK  
LINEAR SHAFTS AND BALL BUSHINGS  
AXE SI RULMENTI LINIARI

► LME\_OP SOROZAT / LME\_OP SERIES / SERIA LME\_OP

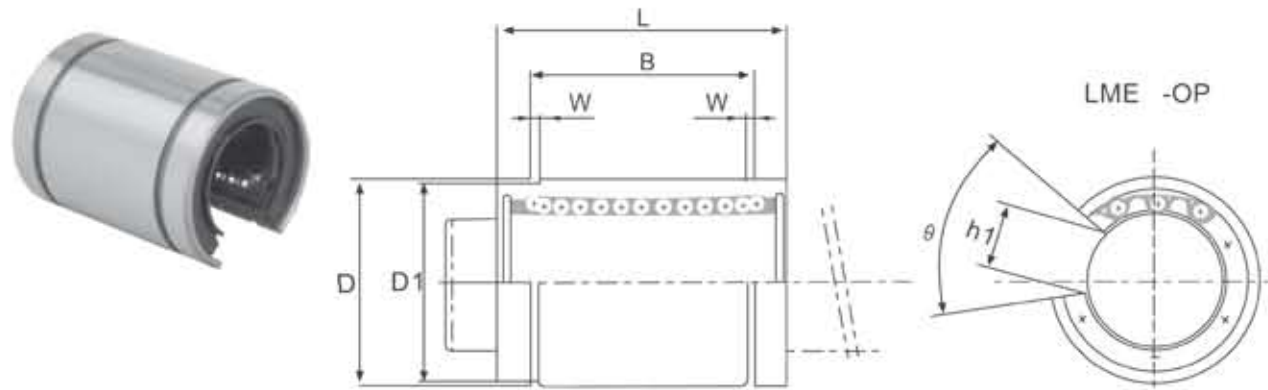

Típus Type Tipul	Golyó sorok Ball circuit Circuitul de bile	dr		D		L		B		D1	W	h1	Θ	Excentri- kusság Eccentri- city Excentri- citate (max.)	Radiális eltérés Radial clearance Abatere radiala (max.)	Terhelés Load Sarcina		Tömeg Weight Masa
		(mm)	(μm)	(mm)	(μm)	(mm)	(μm)	(mm)	(μm)	(mm)	(mm)	(mm)	(μm)			(N)	(N)	
LME12UU-OP	3	12		22	0	32		22,9		21	1,3	7,5	78°			510	784	45
LME16UU-OP	4	16	+9	26	-9	36		24,9		24,9	1,3	10	78°	-4		578	892	60
LME20UU-OP	4	20	+1	32		45		31,5		30,3	1,6	10	60°			862	1370	102
LME25UU-OP	5	25	+11	40	0	58		44,1		37,5	1,85	12,5	60°	15	-6	980	1570	235
LME30UU-OP	5	30	-1	47	-11	68	0	52,1		44,5	1,85	12,5	50°		-8	1570	2740	360
LME40UU-OP	5	40		62	0	80	-300	60,6	0	59	2,15	16,8	50°	17		2160	4020	770
LME50UU-OP	5	50	+13	75	-13	100		77,6	-400	72	2,65	21	50°			3820	7940	1250
LME60UU-OP	5	60	-2	90	0/-15	125	0/-400	3,15		86,5	3,15	27,2	54°	20	-13	4700	9800	2220

LINEÁRIS TENGELEK ÉS CSAPÁGYAK  
LINEAR SHAFTS AND BALL BUSHINGS  
AXE SI RULMENTI LINIARI

► SME SOROZAT / SME SERIES / SERIA SME

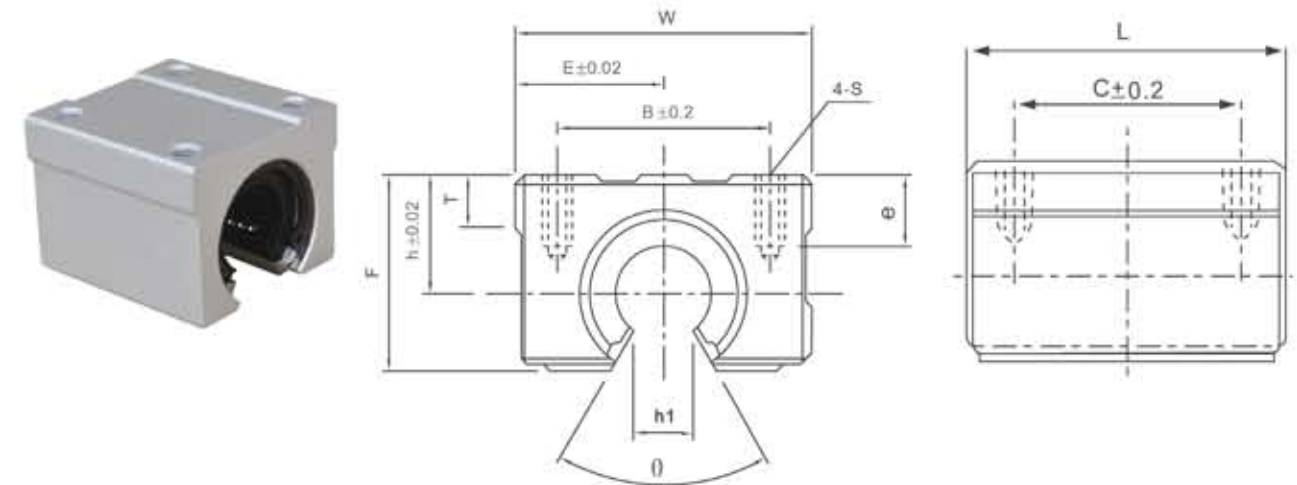

Típus Type Tipul	h	D	W	L	F	T	h1	Θ	B	C	Sxe	Csapágy Bearing Rulment	Terhelés Load Sarcina		Tömeg Weight Masa
													C	C0	
(mm)													(N)	(N)	(g)
SME16UU	20	22,5	45	45	33	9	10	80°	32	30	M5x12	LM16UU-OP	774	1180	150
SME20UU	23	24	48	50	39	11	10	60°	35	35	M6x12	LM20UU-OP	882	1370	200
SME25UU	27	30	60	65	47	14	11,5	50°	40	40	M6x12	LM25UU-OP	980	1570	450
SME30UU	33	35	70	70	56	15	14	50°	50	50	M8x18	LM30UU-OP	1570	2740	630
SME35UU	37	40	80	80	63	18	16	50°	55	55	M8x18	LM35UU-OP	1670	3140	925
SME40UU	42	45	90	90	72	20	19	50°	65	65	M10x20	LM40UU-OP	2160	4020	1330
SME50UU	53	60	120	110	92	25	23	50°	94	80	M10x20	LM50UU-OP	3820	7940	3000

► **SME\_L SOROZAT / SME\_L SERIES / SERIA SME\_L**

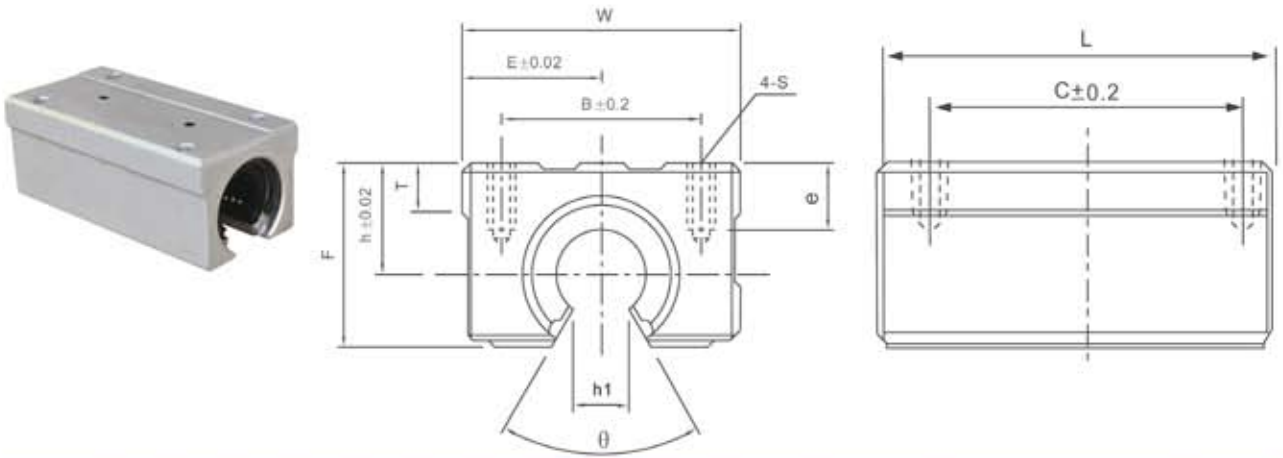

Típus Type Tipul	h	D	W	L	F	T	h1	θ	B	C	Sxe	Csapágy Bearing Rulment	Terhelés / Load / Sarcina		Tömeg Weight Masa
													C	C0	
													(N)	(N)	
(mm)															
SME16LUU	20	22,5	45	85	33	9	10	80°	32	60	M5x12	LM16UU-OPx2	1230	2350	300
SME20LUU	23	24	48	95	39	11	10	60°	35	70	M6x12	LM20UU-OPx2	1400	2740	400
SME25LUU	27	30	60	130	47	14	11,5	50°	40	90	M6x12	LM25UU-OPx2	1560	3140	900
SME30LUU	33	35	70	140	56	15	14	50°	50	100	M8x18	LM30UU-OPx2	2490	5490	1260

► **TBR SOROZAT / TBR SERIES / SERIA TBR**

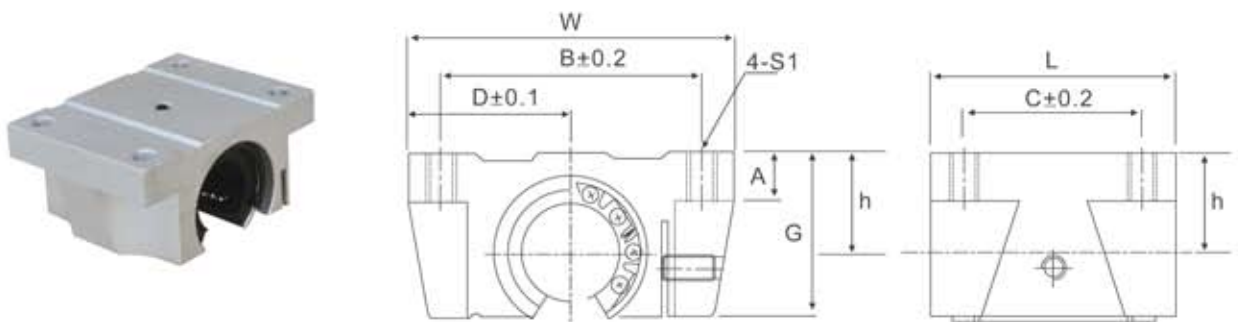

Típus Type Tipul	W	G	A	L	B	D	C	h	S1	Terhelés Load Sarcina		Tömeg Weight Masa
										C	C0	
										(N)	(N)	
(mm)												
TBR16UU	62	26	8	42	50	31	30	18	M5	392	490	180
TBR20UU	68	31	10	51	54	34	37	21	M6	784	1176	300
TBR25UU	82	41	12	65	65	41	50	28	M8	1568	2352	600
TBR30UU	91	48	12	75	75	45,5	60	33,5	M8	1764	2940	900